

S

SERIES

Spring Return Fail-safe Electric Valve Actuators

The logo for Sun Yeh, featuring a stylized green 'S' followed by the word 'SUNYEH' in blue. The 'E' in 'SUNYEH' is uniquely designed with a white arrow pointing to the right.

OPERATION MANUAL



SUN YEH ELECTRICAL IND. CO., LTD.

SY02-CA01A1-EN

Contents

| | | |
|-----|---|----|
| 1 | General Information | 1 |
| 1.1 | Safety Instructions | 1 |
| 1.2 | Installation Notices | 1 |
| 1.3 | Inspection, Storage, Transport | 2 |
| 2 | Product Overview..... | 3 |
| 2.1 | Features..... | 3 |
| 3 | Product Mechanical Data | 3 |
| 3.1 | Parts Identification..... | 3 |
| 3.2 | Technical Information..... | 4 |
| 3.3 | Mounting Base Details | 4 |
| 3.4 | Sizing | 5 |
| 3.5 | Duty Cycle – IEC..... | 5 |
| 4 | Mounting and Setup | 7 |
| 4.1 | Manual Device Installation..... | 7 |
| 4.2 | Manual Device Indication Instruction | 8 |
| 4.3 | Valve Mounting Instructions..... | 9 |
| 4.4 | Wiring Instructions | 10 |
| 4.5 | Actuator Set-up..... | 11 |
| 5 | On / Off Control and Floating Control Board Adjustment..... | 19 |
| 5.1 | On / Off Control Board Surface..... | 19 |
| 5.2 | Troubleshooting of On / Off Controller..... | 20 |
| 5.3 | Floating Control Board Surface..... | 21 |
| 5.4 | Troubleshooting of Floating Controller..... | 22 |
| 6 | Modulating Control Board Adjustment..... | 23 |
| 6.1 | Modulating Control Board Surface | 23 |
| 6.2 | Programming | 23 |
| 6.3 | Dip Switch Setting (SW1) | 24 |
| 6.4 | P4 Terminal..... | 26 |
| 6.5 | Sensitivity Switch Setting (SW2) | 27 |
| 6.6 | Signal Settings for OPEN and CLOSE Position..... | 28 |
| 6.7 | Troubleshooting of modulating controller | 29 |
| 7 | Troubleshooting..... | 31 |
| 8 | Actuator Options | 33 |
| 9 | Warranty | 34 |
| 10 | Disposal..... | 34 |

1 General Information

⚠ Failure to follow safety instructions may cause serious injury, equipment damage, or voided warranty.

1.1 Safety Instructions

- Installation, maintenance and repair works must be performed by trained personnel.
- The handling shall follow the safety and warning instruction contained in this manual.
- Before operation, the user should read and follow instructions contained in this operation manual. Failure to do this may result in damages and void warranty. Sun Yeh will not be liable for damages due to operator negligence or misuse.
- Local health and safety legislation shall be complied with.
- In a few cases, the surface temperature may exceed 60 °C (140 °F). Please check the surface temperature before operation, using an appropriate thermometer and wearing protective gloves before operation.

1.2 Installation Notices

**⚠ Operating by handwheel:
Do not use any tools to increase force on handwheel for operating as this may damage the actuator or valve.**

⚠ DO NOT APPLY POWER BEFORE the actuator fully spring returns.

- The standard spring return actuator rotates counter-clockwise with power (spring compressed) and rotates clockwise with spring released (fully-closed or fully-open) when power outage.
- Please read operation manual and wiring diagram carefully before installation.
- Verify that supply voltage is in accordance with the data on nameplate to prevent short circuit or electrical/electronic parts damage caused by incorrect power input.
- Turn power off before wiring or maintenance.
- Connect the ground wire to PE point inside the actuator.
- To avoid functional failure caused by static, do not touch any components on the PCBA with metal tools or bare hands.
- Do not parallel wire multiple actuators together without using an extra relay.
- Use suitable water-proof cable gland to ensure it fits the conduit entry size, diameter of the cable and the enclosure protection of the actuator when wiring. The water-proof cable gland must be tightened and flattened to the cable after wiring procedure and use original black water-proof plug to seal unused conduit entry and fasten the top cover of the actuator to prevent dust or water from entering the actuator. The red plastic dust-proof plug is not meant for long-term use. Replace it with suitable water-proof connector to ensure the enclosure protection rating.
- After manual operation, the actuator shall be returned to its spring released position by handwheel before electrical operation of the actuator.

- Actuator should be installed in an upright or horizontal position. Do not mount upside down or below a horizontal position.
- These units are not designed to operate in vacuum spaces or where an explosive atmosphere exists.
- Periodically inspect actuator enclosure to prevent dust from accumulating

1.3 Inspection, Storage, Transport

1.3.1 Receiving / Inspection

- Carefully inspect the package for any damages resulting from shipping and report all damages to the freight carrier and seller.
- After unpacking the product and information packet, please keep the cartons and any packing materials in case of product return or replacement. Verify that the items listed in packing slip or in bill of lading are the same as what were ordered. If there is any discrepancy, please contact the seller.
- Verify that the technical data on nameplate is in accordance with what was ordered.

1.3.2 Storage

- The actuator should be stored in a dry area with relative humidity of less than 90 % and at temperatures between 20 °C to +40 °C (4 °F to +104 °F)
- The product shall be stored with suitable protection from corrosive substance that can damage the metal and insulating parts.
- The red dustproof plug and black waterproof plug should not be removed until the actuator is ready to be cabled. Use suitable cable glands with IP 68 protection when wiring and seal the unused cable entry with original black waterproof plug.

1.3.3 Transport

- Attach ropes or hooks for the purpose of lifting by hoist only to housing and not to handwheel.
- Actuators packaged in cartons can stand up to land, sea, or air transportation.
- Packaged actuators shall avoid of violent impact and strong vibrations and be protected from rain or snow.

1.3.4 Lubrication

- The gear train has been sufficiently lubricated at the factory. No additional lubrication is required.

2 Product Overview

S series spring return fail-safe electric actuators offer torque ranges from 50 Nm to 360 Nm (445 in-lb to 3185 in-lb) and are designed for fail-safe positioning of valves or dampers upon loss of supply voltage, which include On / Off control, floating control and modulating control. A rack and pinion spring mechanism is used to position the controlled device to either fully OPEN or fully CLOSED position without any external power source. For On / Off type, a mechanical BUFFER is used at the end of the spring stroke to reduce the hammer-blow effects in pipes. A clutch-less manual override is optional to provide manual positioning of the controlled device.

2.1 Features

- Controls: On / Off, floating (optional), modulating (optional).
- Clutch-less manual override (optional).
- Dry-powder coated aluminum alloy enclosure conforms to C3, NEMA Type 4X, 5 & IP 68 outdoor use.
- ISO 5211 mounting flange.
- Domed position indicator.
- Built-in motor thermal protection.

3 Product Mechanical Data

3.1 Parts Identification

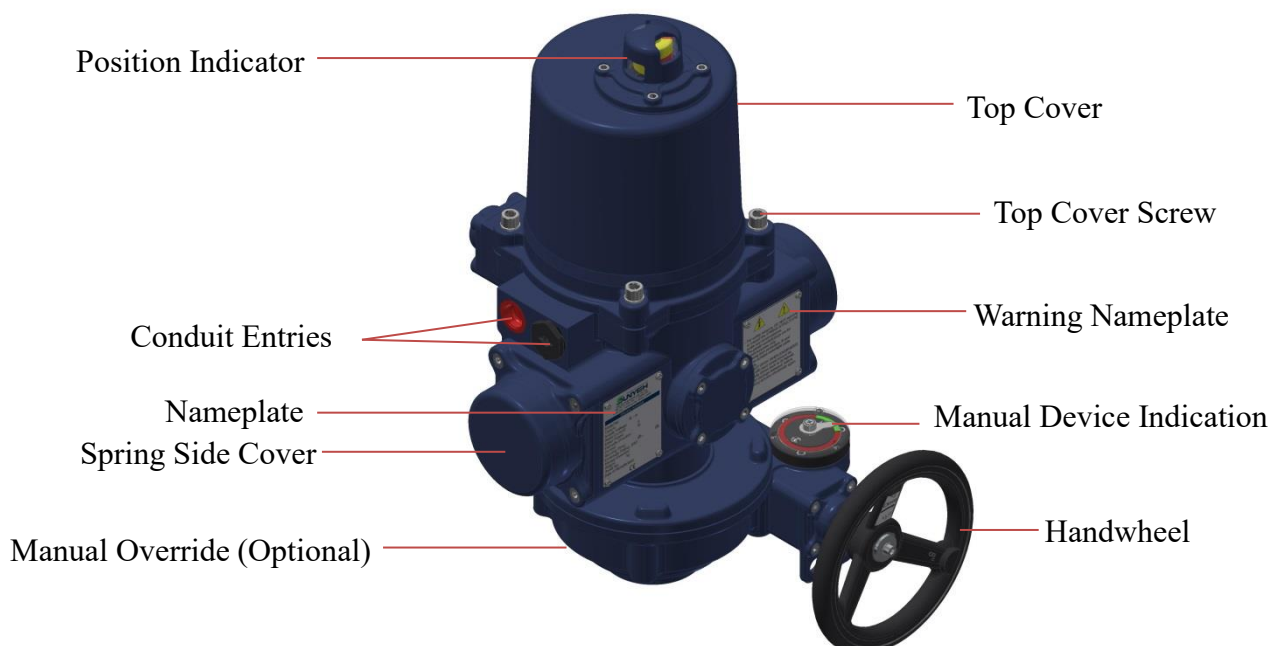

3.2 Technical Information

| Model | Torque | | Motor Power | Weight | | | |
|--------|--------|-------|-------------|----------|-----|---------------------|-----|
| | | | | Standard | | w / Manual Override | |
| | Nm | in-lb | | W | kg | lb | kg |
| S-500 | 50 | 445 | 50 | 27 | 60 | 37 | 82 |
| S-1300 | 130 | 1150 | 130 | 57 | 126 | 77 | 170 |
| S-2000 | 200 | 1770 | 130 | 93 | 205 | 131.5 | 290 |
| S-2600 | 260 | 2300 | 130 | 95 | 210 | 133.5 | 295 |
| S-3600 | 360 | 3185 | 130 | 103 | 228 | 152 | 336 |

3.3 Mounting Base Details

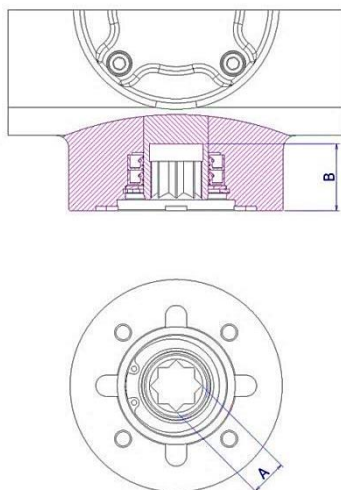

| Model | Flange Type | Output Drive (A) | | Depth of Output Drive (B) | |
|--------|-------------|------------------|-------|---------------------------|-------|
| | ISO 5211 | mm | inch | mm | inch |
| S-500 | F07 | 17 | 0.669 | 30 | 1.181 |
| S-1300 | F10 | 22 | 0.866 | 41 | 1.614 |
| S-2000 | F12 | 27 | 1.063 | 45 | 1.772 |
| S-2600 | F12 | 27 | 1.063 | 45 | 1.772 |
| S-3600 | F12 | 36 | 1.417 | 46 | 1.811 |

3.4 Sizing

⚠ For safety reasons, do not remove or inspect the SPRING STRUCTURE. Proper tools must be used, or serious injury will occur.

The actuator shall be sized to ensure that its torque output meets the load requirements of valve. (As a MINIMUM, a 30% safety factor is suggested for the calculation of torque requirement).

- If the maximum torque of 5" valve is 80 Nm → $80 \times 1.3 = 104$ Nm
104 Nm < 130 Nm (S-1300) → OK!
 104 Nm > 50 Nm (S-500) → Not OK!

3.5 Duty Cycle – IEC

- The duty cycle is the relationship between the running time and resting time. It is calculated as below:

$$\text{Duty Cycle} = \frac{\text{Running Time (Sec)}}{\text{Running Time (Sec)} + \text{Rest Time (Sec)}} \times 100 \%$$

➔ $\text{Rest Time (Sec)} = \frac{\text{Running Time (Sec)} \times (1 - \text{Duty Cycle})}{\text{Duty Cycle}}$

- **If the motor running time is 10 sec, spring return time is 5 sec, 50% duty cycle, the rest (off) time shall be calculated as below:**
 - ✓ Motor running time $10 \text{ sec} \times (1 - 50 \%) / 50 \% = 10$, rest time is 10 sec.
 - ✓ Spring return time $5 \text{ sec} \times (1 - 50 \%) / 50 \% = 5$, rest time is 5 sec.
 - ⚠ **One cycle consists of open-rest-close-rest.**
 - ⚠ **A rest time is required after spring returned because the gear train and motor are driven during spring released.**

【S Series】 Spring Return Fail-safe Electric Valve Actuators

- Ambient temperature and rated duty cycle :

Standard Ambient Temperature:

| Model | Controls | Duty Cycle v.s. Ambient Temperature |
|---|----------------------|--|
| S-500 / S-1300 / S-2000 / S-2600 / S-3600 | On / Off Floating | -30°C to +65°C (-22°F to +149°F) Remarks: 50% Duty Cycle: -30°C to +40°C (-22°F to +104°F) 30% Duty Cycle: +41°C to +65°C (+105°F to +149°F) |
| S-500 / S-1300 / S-2000 / S-2600 | Modulating | -20°C to +65°C (-4°F to +149°F) Remarks: 50% Duty Cycle: -20°C to +40°C (-4°F to +104°F) 30% Duty Cycle: +41°C to +65°C (+106°F to +149°F) |

Low Ambient Temperature:

| Model | Controls | Duty Cycle v.s. Ambient Temperature |
|-------------------------------------|----------------------|--|
| S-500 / S-1300 / S-2000 / S-2600 | On / Off Floating | -40°C to +65°C (-40°F to +149°F) Remarks: 50% Duty Cycle: -40°C to +40°C (-40°F to +104°F) 30% Duty Cycle: +41°C to +65°C (+105°F to +149°F) |
| S-3600 | Floating | -40°C to +65°C (-40°F to +149°F) Remarks: 50% Duty Cycle: -40°C to +40°C (-40°F to +104°F) 30% Duty Cycle: +41°C to +65°C (+105°F to +149°F) |

4 Mounting and Setup

4.1 Manual Device Installation

- a. Slide fixing screw through washers and handwheel and secure them to override shaft as shown in the figure below.

⚠ Turn off power when installing handwheel.

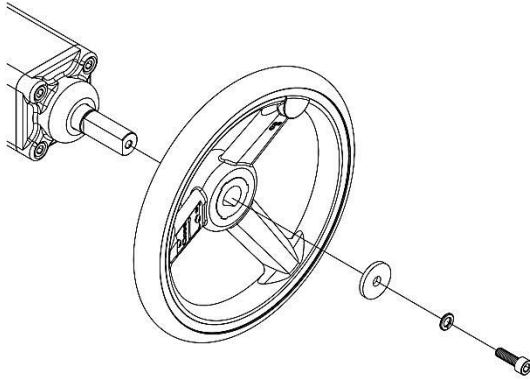

- b. Assembly completed as shown in the figure below.

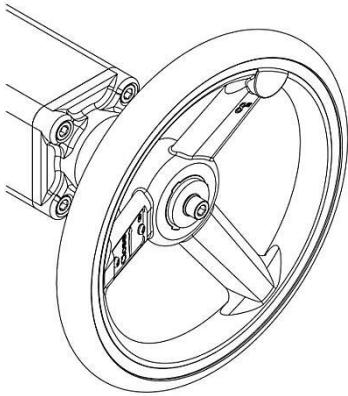

4.2 Manual Device Indication Instruction

- Pointer Indication:

⚠ If the actuator could not operate when supplying power, use the manual override to rotate the pointer to the green zone for normal operation.

Red Zone: Actuator cannot operate normally when supplying power.

Green Zone: Actuator can operate normally when supplying power.

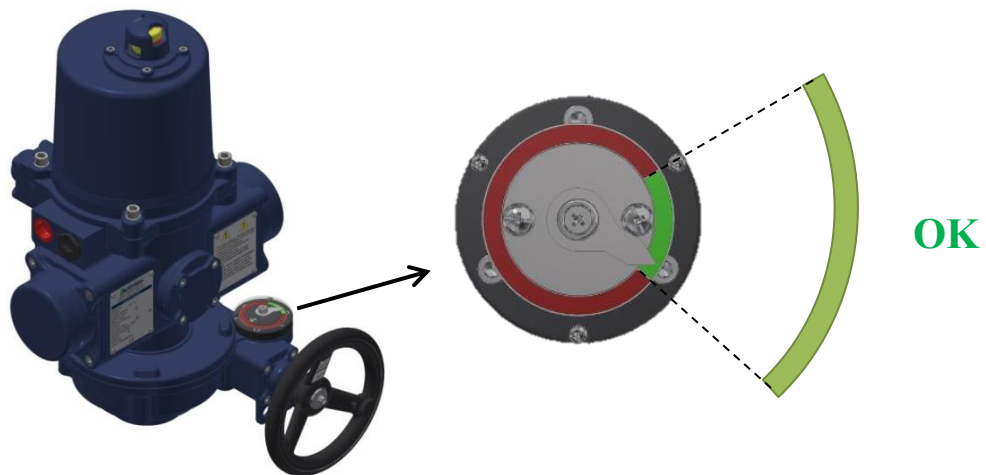

4.3 Valve Mounting Instructions

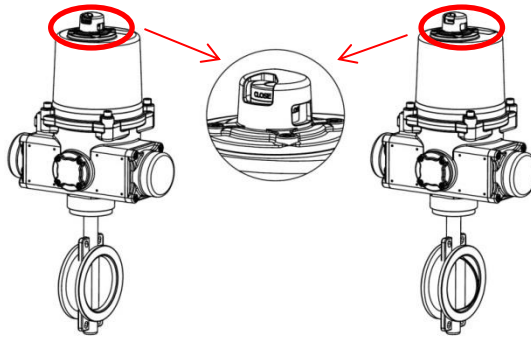

- a. The spring return actuator is shipped in spring return position (spring released) with the configuration of spring clockwise and fully-closed when power outage unless specified. Refer to section 8 to ensure actuator selected meets the application.
- b. The valve or damper must be rotated to fully-closed position before mounting with actuator if FAIL POSITION is fully-closed and vice versa.
- c. Remove all of valve handle parts, for example, the handle or open/close mechanical stops so as to not interfere with the actuator.
⚠ Do not remove packing gland or other parts necessary for operation from valve.
- d. Check again that the valve and actuator are in the same position (fully-open or fully-closed).
- e. Once mounted together, either directly or with a mounting kit, ensure that they are properly secured together and all fasteners are tightened.
- f. Remove the conduit entry plug to relieve the pressure inside the actuator for the ease of the top cover removal and gently remove the cover.
⚠ The power must be off before removing the cover.
- g. Refer to section 4.4 for wiring notices and connect the wires according to the wiring diagram labeled inside the cover of actuator.
- h. Supply power to actuator.
⚠ Care must be taken at all times as there are live circuits present that may cause electrical shock.
- i. Re-calibration may be required for the end positions, refer to section 4.5 (P.11 to 18) for further instructions.
- j. Assemble the cover and secure cover screws firmly after setting.
⚠ Please ensure that the O-ring seal is in good condition prior to cover installation.

4.4 Wiring Instructions

⚠ Turn power off before making the electrical connection!

- Connect the ground wire to PE point placed on middle metal plate wiring according to the wiring diagram inside the top cover.
- Each actuator is attached with a black water-proof plug and a temporary red dust-proof plug to conduit entries.
 - ⚠ **Use correct size of fittings so as to not damage the threads.**
- Verify the supply power is in accordance with the data on the nameplate to prevent a short circuit and an electrical shock.
 - ⚠ **Do not apply power to actuator before wiring, otherwise it can cause an electrical shock or damage components of the actuator.**
- The red plastic dustproof plug is not meant for long-term use. Use suitable cable glands with IP 68 protection when wiring and seal the unused cable entry with original black waterproof plug.

4.5 Actuator Set-up

- ⚠ If the actuator is equipped with a manual override, rotate the handwheel to return the actuator to its spring released position before the power is supplied.**
- ⚠ Securely tighten the conduit fittings to ensure the enclosure protection rating.**
- ⚠ DO NOT APPLY POWER BEFORE the actuator fully spring returns.**

The spring return actuator provides fail-safe positioning and the end stop position of spring return is determined by either buffer or end stop (On/Off by the buffer, floating or modulating limited by end stop). When the actuator is motorized, the end position is determined by limit switches.

The actuator has been set and calibrated at the factory. Most of products will not require recalibration of these settings. However these are general settings. After valve and actuator are bolted together, apply power to drive the actuator to its fully-open (spring compressed). Then remove power to let the rack and pinion spring mechanism drive back to its fully-closed position. If the OPEN or CLOSE stop point are not aligned with valve or damper correctly, its end positions must be adjusted. Please follow steps below:

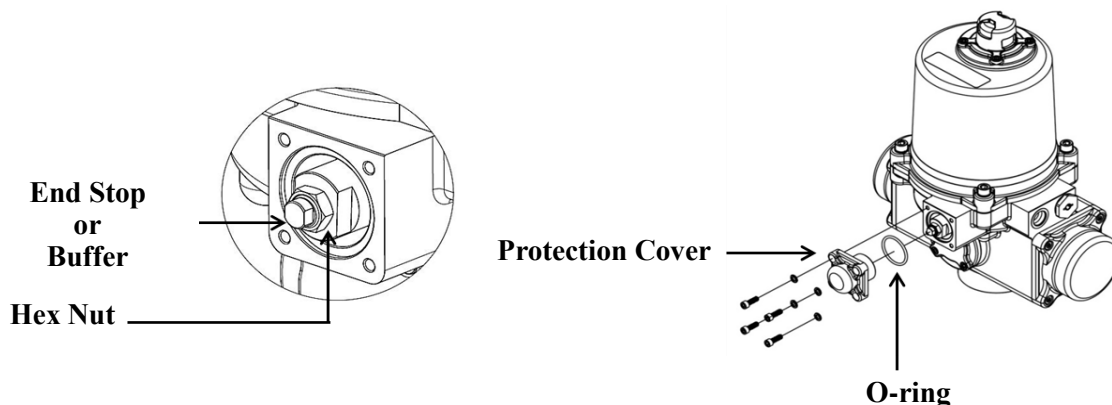

- ⚠ For modulating unit, ensure to loosen the sector gear of potentiometer first before adjusting the following settings.**

4.5.1 Adjustment procedure for spring-return actuator in the fail-closed position upon loss of supply voltage.

● Adjust FULLY-CLOSED (spring released) stop point as steps below:

- a. Turn power off and loosen the protection cover using a 5 mm hex key.
- b. Adjust the hex nut, buffer or end stop.
 - S-500: Loosen the hex nut counterclockwise using a 22 mm open-end wrench, and adjust the buffer or end stop simultaneously using a 10 mm open-end wrench.
 - S-1300 to S-3600: Loosen the hex nut counterclockwise using a 32 mm open-end wrench, and adjust the buffer or end stop simultaneously using a 22 mm open-end wrench.
- c. Turn the buffer or end stop to adjust the fully-closed stop point.

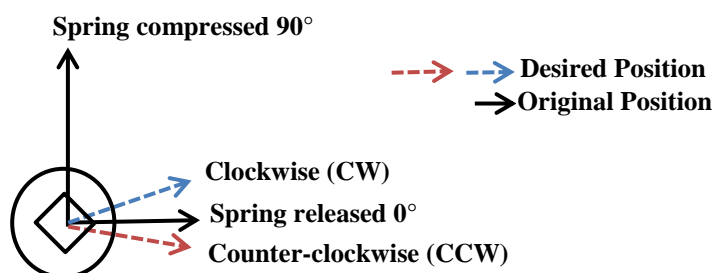



- S-500 : One turn = 2.3 degrees
 - S-1300 to S-3600 : One turn = 1.4 degrees
- d. Once completed, tighten the hex nut, replace the protection cover and tighten all screws.
 - ⚠ **If the buffer or end stop is adjusted, TC2 must be reset in accordance with the buffer or the end stop.**
 - e. Loosen the M3 cap screw of cam **TC2** with a 2.5 mm hex key.
 - f. Rotate the cam TC2 counter-clockwise until a light click is heard, and then slowly rotate the cam TC2 clockwise until a light click is heard, so that LS2 is not triggered.

【 S Series 】 Spring Return Fail-safe Electric Valve Actuators

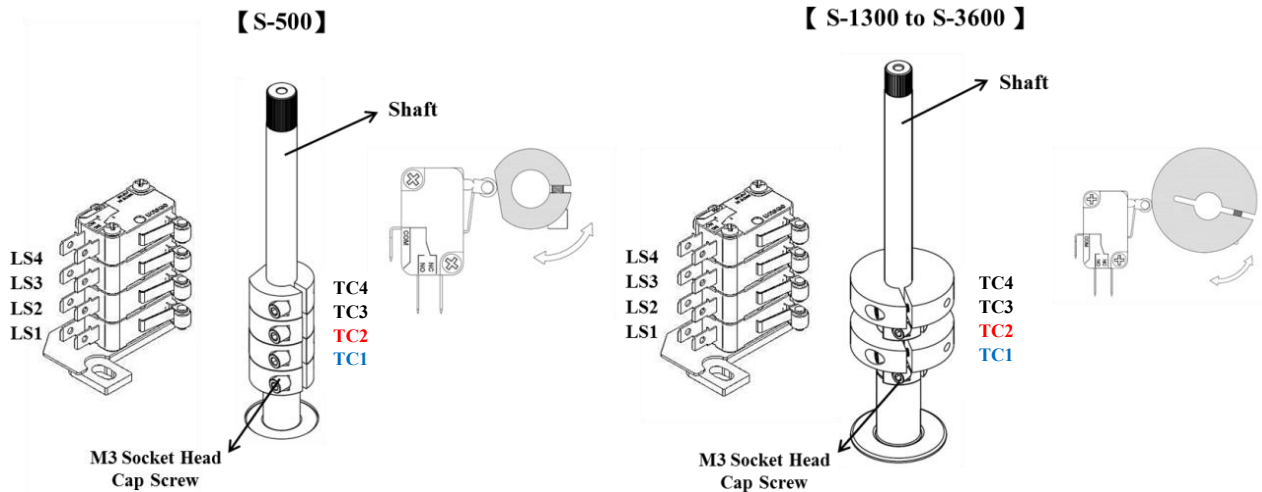
g. Tighten the cap screw of cam **TC2**.



TC2 is utilized for sensing fully-closed stop point. Once the spring mechanism has been released when power outage, the actuator will not drive under power again until it has reached its fail stop position and **TC2** is not triggering LS2.

TC1 "OPEN"  Clockwise: increase opening degree.
 Counter-clockwise: decrease opening degree.

Note:

- LS2 shall trip while **TC2** reaches the end stop point.
- TC3 & TC4 are optional, refer to P.12 & P.15 section 4.4.1 (f.) and 4.4.2 (f.) for calibration.

Dry contact sequence diagram (LS3 & LS4)

【 S-500 to S-3600 】

| Symbol | Contact | Position | |
|----------------------|---------|----------|--------|
| | | 100% | 0% |
| LS4 (Dry Contact) | D - F | ----- | ●----- |
| | D - E | ----- | ●----- |
| LS3 (Dry Contact) | A - C | ●----- | ----- |
| | A - B | ●----- | ----- |

- Solid line (—) : Dry contact in conductive state.
- Dotted line (---) : Dry contact in non-conductive state.

【S Series】 Spring Return Fail-safe Electric Valve Actuators

- **Adjust FULLY-OPEN (spring compressed) stop point as steps below:**
 - a. Apply power to drive the actuator to its fully-open (spring compressed) position. If the open stop point is not aligned with the valve or damper properly, then it must be adjusted.
 - b. Remove power to let spring system to drive back to its fully-closed (spring released) position.
 - c. If it is required to adjust, loosen the cap screw of cam **TC1** with a 2.5 mm hex key.
 - To increase the opening angle, turn the cam clockwise.
 - To decrease the opening angle, turn the cam counter-clockwise.

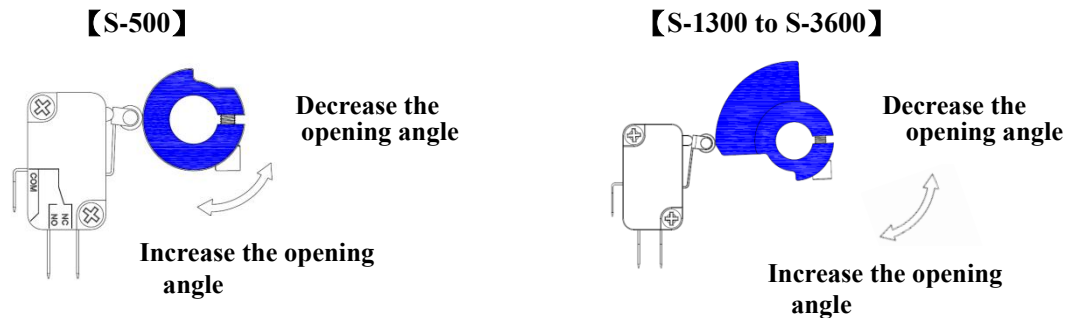

- d. After adjusting the cam, apply power to drive the actuator to the fully-open position.
- e. Verify that it is in the correct fully-open position.
 - If it is in correct position, remove power and lock the cap screw of cam **TC1**.
 - If it is not in correct position, repeat step C until the correct position is reached.
- f. If auxiliary switches will be used for feedback, cams TC3 and TC4 need to be calibrated.
 - Adjust cam TC3 so it trips just before cam TC1 does.
 - Adjust cam TC4 so it trips just before cam TC2 does.

4.5.2 Adjustment procedure for spring-return actuator in the fail-open position upon loss of supply voltage.

- **Adjust FULLY-OPEN (spring released) stop point as steps below:**
 - a. Turn power off and loosen the protection cover using a 5 mm hex key..
 - b. Adjust the set hex nut, buffer or end stop.
 - S-500: Loosen the hex nut counterclockwise using a 22 mm open-end wrench, and adjust the buffer or end stop simultaneously using a 10 mm open-end wrench.
 - S-1300 to S-3600: Loosen the hex nut counterclockwise using a 32 mm open-end wrench, and adjust the buffer or end stop simultaneously using a 22 mm open-end wrench.
 - c. Turn the buffer or end stop to adjust the fully-open stop point.

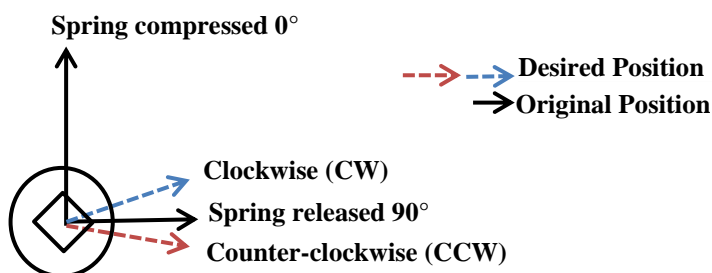



- S-500 : One turn = 2.3 degrees
- S-1300 to S-3600 : One turn = 1.4 degrees
- d. Once completed, tighten the hex nut, replace the protection cover and tighten all screws.
 - ⚠ **If the buffer or end stop is adjusted, TC2 must be reset in accordance with the buffer or the end stop.**
- e. Loosen the M3 cap screw of cam TC2 with a 2.5 mm hex key.
- f. Rotate the cam **TC2** counter-clockwise until a light click is heard, and then slowly rotate the cam **TC2** clockwise until a light click is heard, so that LS2 is not triggered.

【 S Series 】 Spring Return Fail-safe Electric Valve Actuators

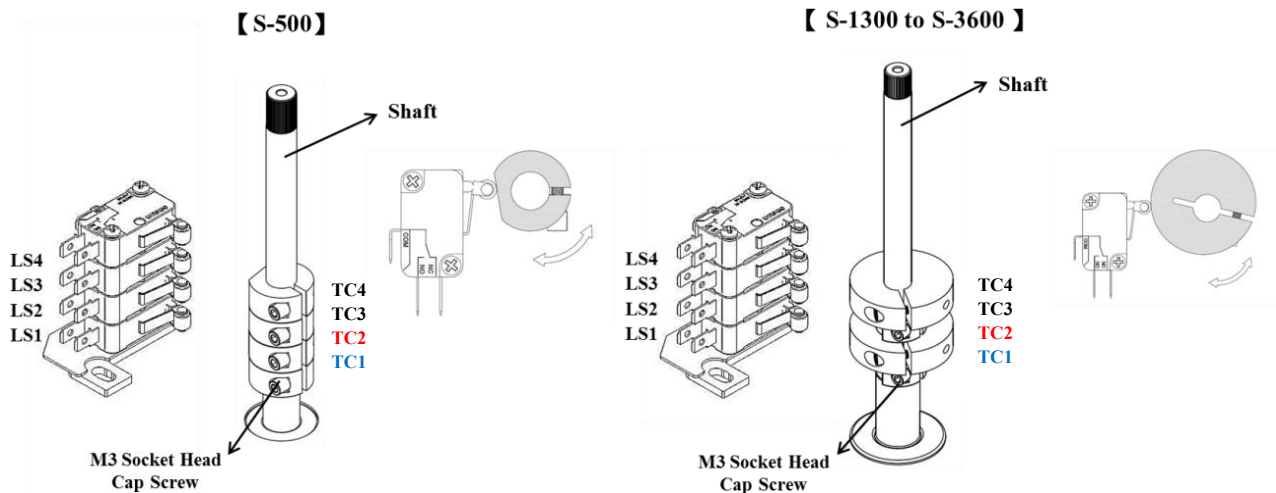
g. Tighten the cap screw of cam **TC2**.



TC2 is utilized for sensing fully-closed stop point. Once the spring mechanism has been released when power outage, the actuator will not drive under power again until it has reached its fail stop position and **TC2** is not trigger LS2.

TC1 "OPEN"  Clockwise: increase closing degree.
 Counter-clockwise: decrease closing degree.

Note:

- LS2 shall trip while **TC2** reaches the end stop point.
- TC3 & TC4 are optional, refer to P.12 & P.15 section 4.4.1 (f.) and 4.4.2 (f.) for calibration.

Dry contact sequence diagram (LS3 & LS4)

【 S-500 to S-3600 】

| Symbol | Contact | Position | |
|----------------------|---------|----------|--------|
| | | 100% | 0% |
| LS4 (Dry Contact) | D - F | ----- | ●----- |
| | D - E | ----- | -----● |
| LS3 (Dry Contact) | A - C | ●----- | ----- |
| | A - B | ----- | -----● |

- Solid line (—) : Dry contact in conductive state.
- Dotted line (---) : Dry contact in non-conductive state.

【S Series】 Spring Return Fail-safe Electric Valve Actuators

- **Adjust FULLY-CLOSED (spring compressed) stop point as steps below:**
 - a. Apply power to drive the actuator to its fully-closed (spring compressed) position. If the close stop point is not aligned with the valve or damper properly, then it must be adjusted.
 - b. Remove power to let spring system to drive back to its fully-open (spring released) position.
 - c. If it is required to adjust, loosen the cap screw of cam **TC1** with a 2.5 mm hex key.
 - To increase the closing angle, turn the cam clockwise.
 - To decrease the closing angle, turn the cam counter-clockwise.

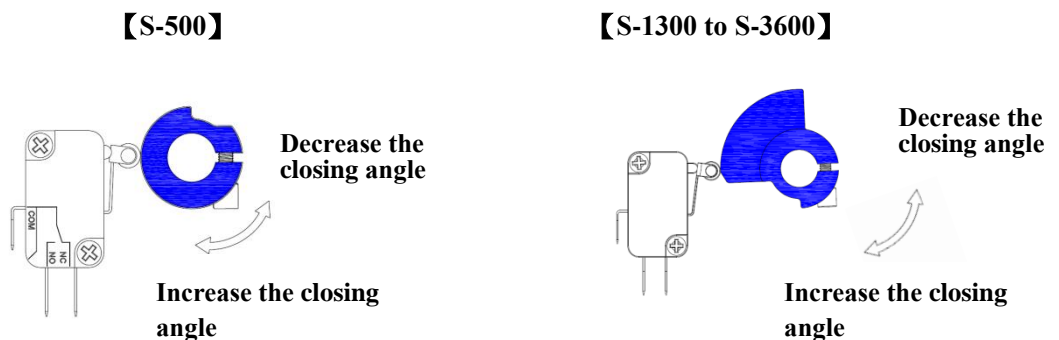

- d. After adjusting the cam, apply power to drive the actuator to the fully-closed position.
- e. Verify that it is in the correct fully-closed position.
 - If it is in correct position, remove power and lock the cap screw of cam **TC1**.
 - If it is not in correct position, repeat step C until the correct position is reached.
- f. If auxiliary switches will be used for feedback, cams TC3 and TC4 need to be calibrated.
 - Adjust cam TC3 so it trips just before cam **TC1** does
 - Adjust cam TC4 so it trips just before cam **TC2** does.

4.5.3 Modulating Control Actuators Potentiometer Setting

- For modulating actuators, after completing the calibration, turn the actuator to fully-closed or fully-open position (spring released) and follow the procedure below:

Fail clockwise (CW) rotation

- Loosen M5 set screw.
- Rotate sector gear clockwise to the position shown in figure below.
⚠️ Ensure that round gear and sector gear are engaged properly.
- Tighten M5 set screw.

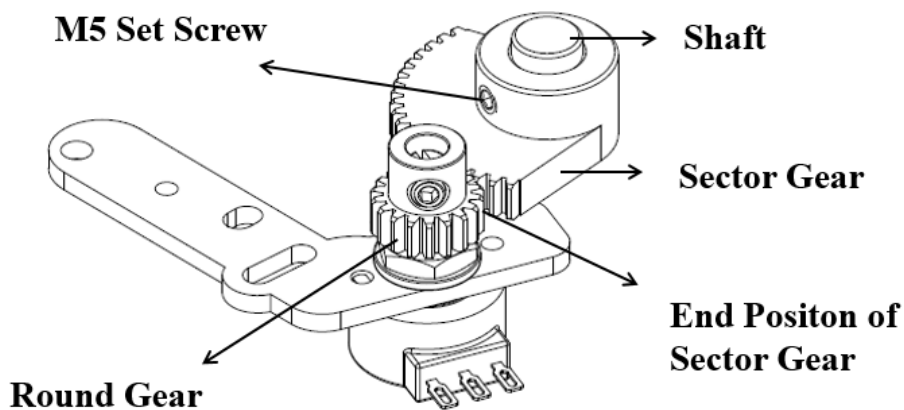

Fail counter-clockwise (CCW) rotation

- Loosen M5 set screw.
- Rotate sector gear counter-clockwise to the position shown in figure below.
⚠️ Ensure that round gear and sector gear are engaged properly.
- Tighten M5 set screw.

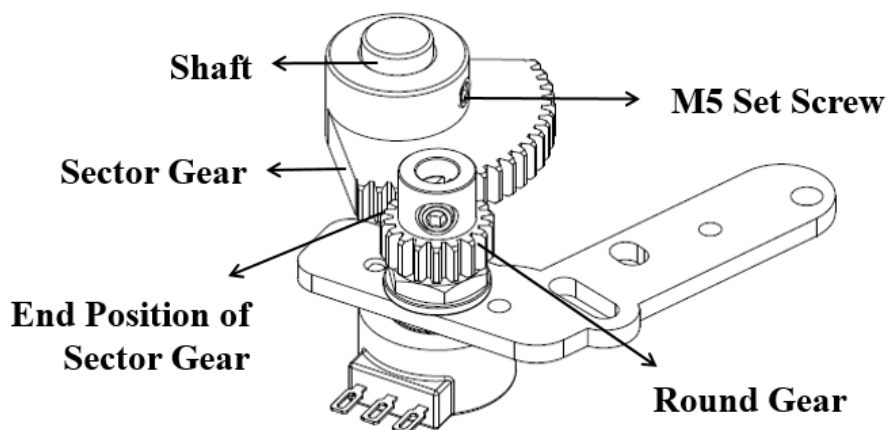

5 On / Off Control and Floating Control Board Adjustment

5.1 On / Off Control Board Surface

The layout is based on 110 / 220V.

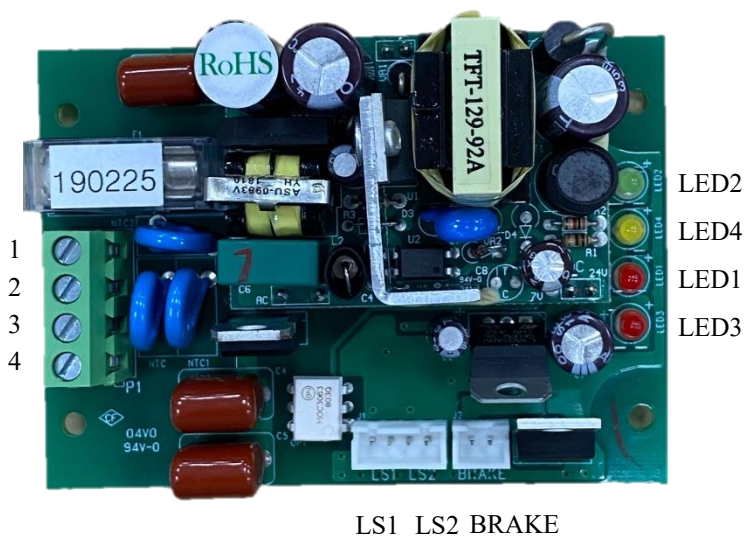

- **Indicator Lamp**

| Lamp No. | Status |
|----------|-----------------|
| LED1 | Power |
| LED2 | Operating |
| LED3 | Motor Brake |
| LED4 | Alerting Signal |

5.2 Troubleshooting of On / Off Controller

⚠ In case LED1 to LED3 does not light or LED4 lights when the actuators are motorized, please refer to steps below for basic troubleshooting.

| Status of LEDs | Possible problems | Solution |
|---------------------|---|--|
| LED4 goes on | <ul style="list-style-type: none"> a. LS1 and LS2 terminals loose or poor contact. b. Incorrect connection of the terminal LS1 or LS2. c. The input power failure time is more than 150ms. d. Abnormal setting of limit switches and cams. e. Supply the power again during spring released. f. LS1 and LS2 failed. g. Actuator overload cause it can not returned to spring released position and restart. h. Abnormal setting of cam TC and cause the contact of LS2 can not be released. | <ul style="list-style-type: none"> a. Make sure to connect the PCBA terminals firmly. If it is damaged, please replace new terminals. b. Verify the actuator is wire properly as per wiring diagram. c. Please provide an independent power supply to actuator to avoid unstable power supply and cause the actuator enter to self-protection. d. Please refer to 4.5 (P.11 to P.18) Actuator set-up. e. Power off until the actuator return to spring released position and then supply power again. f. Replace new limit switches. g. Please refer to 3.4 (P.5) Sizing. h. Please refer to 4.5 (P.11 to P.18) Actuator set-up. |
| LED1 does not go on | <ul style="list-style-type: none"> a. Wrong supply voltage. b. Blown fuse. c. PCBA failed. | <ul style="list-style-type: none"> a. Check the power supply is according to the actuator rated voltage. b. Replace a new fuse. c. Replace a new PCBA. |
| LED2 does not go on | <ul style="list-style-type: none"> a. Abnormal Setting for LS1 and LS2. b. PCBA failed. ° | <ul style="list-style-type: none"> a. Check the LED 4, if the LED4 lights please refer to the troubleshooting for LED4. b. Replace a new PCBA. |
| LED3 does not go on | <ul style="list-style-type: none"> a. PCBA failed. | <ul style="list-style-type: none"> a. Replace a new PCBA. |

5.3 Floating Control Board Surface

The layout is based on 110 / 220 V.

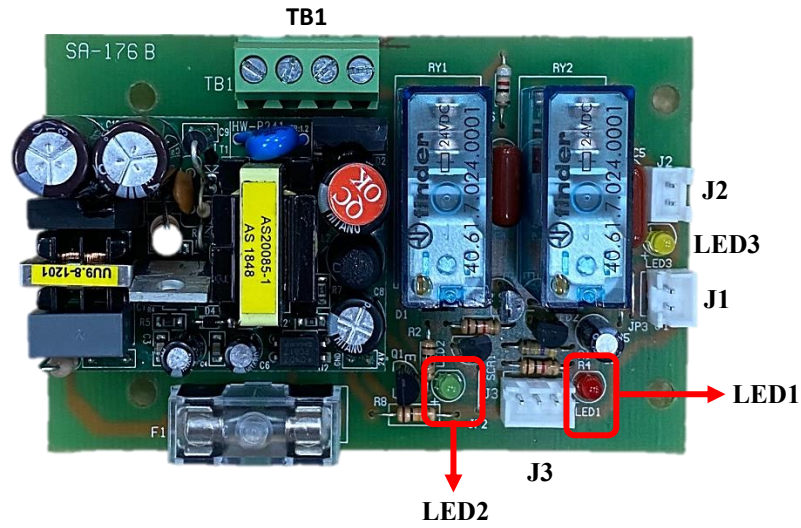

- **Indicator Lamp**

| Lamp No. | Status |
|----------|-------------------|
| LED1 | Spring Released |
| LED2 | Spring Compressed |
| LED3 | Power |

5.4 Troubleshooting of Floating Controller

⚠ In case LED1 to LED3 does not light when the actuator is motorized, please refer to steps below for basic troubleshooting.

| Status of LEDs | Possible problems | Solution |
|---------------------|---|--|
| LED1 does not go on | <ul style="list-style-type: none"> a. Abnormal control signal. b. PCBA failed. c. Abnormal power supplied. d. The terminals loose or damaged. | <ul style="list-style-type: none"> a. Check if the terminal #4 and #6 is conducted. b. Replace a new PCBA ◦ c. Check the power supply is according to the actuator rated voltage. d. Make sure to connect the PCBA terminals firmly. If the terminals are damaged, please replace the PCBA. |
| LED2 does not go on | <ul style="list-style-type: none"> a. Abnormal control signal. b. PCBA failed. c. Abnormal power supplied. d. The cam active the limit switch. e. Incorrect setting of the LS1 and TC1. f. Incorrect connection of LS1. g. The terminals loose or damaged. | <ul style="list-style-type: none"> a. Check if the terminal #4 and #5 is conducted. b. Replace a new PCBA ◦ c. Check the power supply is according to the actuator rated voltage d. It's normal condition, please refer to 4.5(P.11 to P.18) Actuator set-up if need to adjusted. e. Check if the LS1 is conducted when the actuator return to spring released position, if not please refer to 4.5(P.11 to P.18) Actuator set-up. f. Verify the actuator is wire properly as per wiring diagram. g. Make sure to connect the PCBA terminals firmly. If the terminals are damaged, please replace the PCBA. |
| LED3 does not go on | <ul style="list-style-type: none"> a. Abnormal power supply. b. Blown fuse (F1). c. PCBA failed. d. Incorrect setting of the LS2 and TC2. e. Actuator overload. f. Actuator is abnormal and cannot return to spring released position. g. Incorrect connection of LS1. h. The terminals loose or damaged. | <ul style="list-style-type: none"> a. Check the power supply is according to the actuator rated voltage. b. Replace a new fuse. c. Replace a new PCBA. d. Check if the LS2 is conducted when the actuator return to spring released position, if not please refer to 4.5 (P.11 to P.18) Actuator set-up. e. Check if the torque of valve larger than actuator rated torque. f. Contact with factory to replace new actuator. g. Verify the actuator is wire properly as per wiring diagram h. Make sure to connect the PCBA terminals firmly. If the terminals are damaged, please replace the PCBA. |

6 Modulating Control Board Adjustment

6.1 Modulating Control Board Surface

The layout is based on 110 / 220 V.

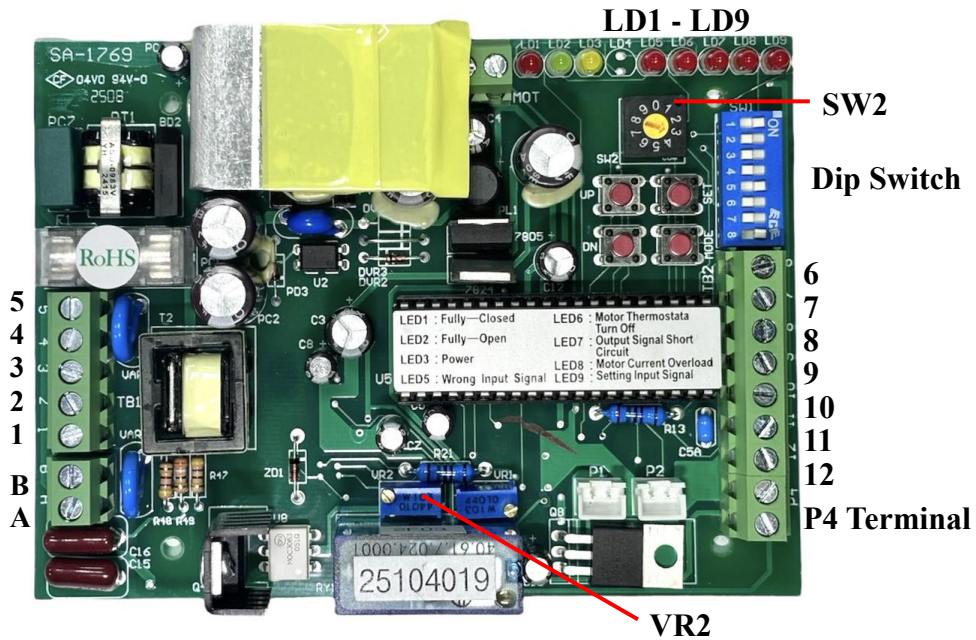

6.2 Programming

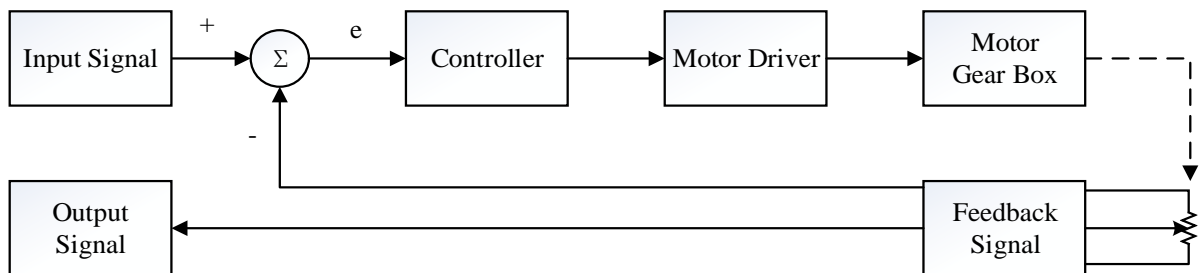

6.3 Dip Switch Setting (SW1)

The Dip Switch SW1 is a combination of 8 switches and equally divided in two rows. It is utilized to select signal type of input as well as output and fail positioning when the input signal fails. The sliders can be placed at either ON (upper) or OFF (lower) state position. Factory default settings are switches 1, 4, 8 at ON state and switches 2, 3, 5, 6, 7 at OFF state.

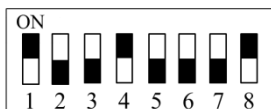

Please follow steps below if an adjustment of these settings are required.

① **Please restart the actuator after adjusting.**

| | 1 | 2 | 3 | 4 | 5 | 6 | 7 | 8 |
|---|-----|-----|-----|-----|-----|-----|-----|-----|
| Default Setting | ON | OFF | OFF | ON | OFF | OFF | OFF | ON |
| 4 - 20 mA input | ON | OFF | | | | | | |
| 1 - 5 V input | OFF | OFF | | | | | | |
| 2 - 10 V input | OFF | ON | | | | | | |
| 4 - 20 mA output | | | OFF | ON | OFF | | | |
| 2 - 10 V output | | | ON | OFF | ON | | | |
| Closing direction setting: CW | | | | | | OFF | | |
| Closing direction setting: CCW | | | | | | ON | | |
| When signal input failed, driving valve to fully-open. | | | | | | | ON | OFF |
| When signal input failed, driving valve to fully-closed. | | | | | | | OFF | ON |
| When signal input failed, valve stays at the last position. | | | | | | | ON | ON |
| | | | | | | | OFF | OFF |

a. Input Signal Setting (switches 1 - 2)

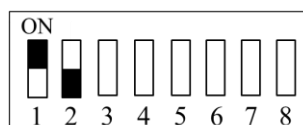

| Input Signal | State of Switches |
|--------------|--------------------|
| 4 - 20 mA | 1 at ON, 2 at OFF |
| 1 - 5 V | 1 at OFF, 2 at OFF |
| 2 - 10 V | 1 at OFF, 2 at ON |

【S Series】 Spring Return Fail-safe Electric Valve Actuators

b. Output Signal Setting (switches 3 - 5)



- Output signal can be fine-tuned by VR2.
- When resetting the Output Signal, be sure to fine-tune VR2 to match either the 2 - 10 V or 4 - 20 mA setting.

| Output Signal | State of Switches |
|---------------|-----------------------------|
| 4 - 20 mA | 3 at OFF, 4 at ON, 5 at OFF |
| 2 - 10 V | 3 at ON, 4 at OFF, 5 at ON |

c. Closing direction setting (switch 6)

- When S6 is set to OFF, the closing direction of output drive is CW (clockwise).
- When S6 is set to ON, the closing direction of output drive is CCW (counter-clockwise).

⚠ The input signal type is set by switches 1 and 2. And switch 6 is used to set the corresponding relationship between value of input signal and operation direction of actuator as shown in the figure below, e.g., 4 - 20 mA input signal.

⚠ The operating direction of the actuator has been set and calibrated at the factory. Be sure to change the direction of the position indicator if different operating direction is required.

When S6 is set to **OFF**

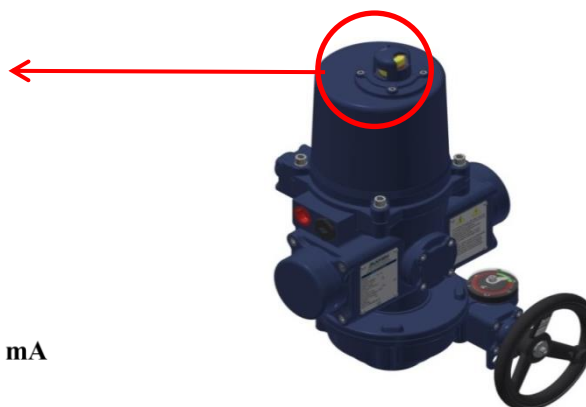
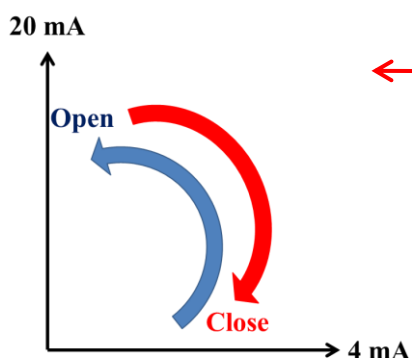
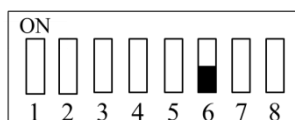

| Position Indicator (Fully-Open→Fully-Closed) | Operating Position | Input Signal | LED | Output Signal |
|---|-----------------------|------------------|--------|------------------|
| CW | Fully-Closed | 1 V, 2 V, 4 mA | LD1 ON | 2 V, 4 mA |
| | Fully-Open | 5 V, 10 V, 20 mA | LD2 ON | 10 V, 20 mA |

【S Series】 Spring Return Fail-safe Electric Valve Actuators

When S6 is set to **ON**

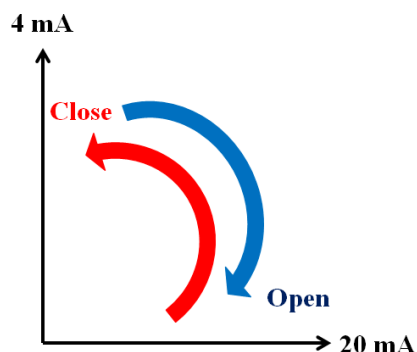
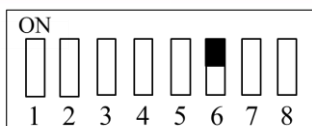

| Position Indicator (Fully-Open→Fully-Closed) | Operating Position | Input Signal | LED | Output Signal |
|---|---------------------|------------------|---------------|---------------|
| CCW | Fully-Closed | 1 V, 2 V, 4 mA | LD1 ON | 2 V, 4 mA |
| | Fully-Open | 5 V, 10 V, 20 mA | LD2 ON | 10 V, 20 mA |

d. Failed position setting while the input signal failed. (switches 7 and 8)

- When a low signal value is received, the actuator operates toward fully-closed position and when a high signal value is received, the actuator operates toward fully-open position.

| Input Signal | Fully-Closed | Fully-Open |
|--------------|--------------|------------|
| 4 - 20 mA | 4 mA | 20 mA |
| 1 - 5 V | 1 V | 5 V |
| 2 - 10 V | 2 V | 10 V |

- The selection of the fail position while the input signal failed, please follow table below:

| Signal Failed Position | State of Switch |
|------------------------|--|
| Fully-Open | 7 at ON, 8 at OFF |
| Fully-Closed | 7 at OFF, 8 at ON |
| The Last Position | 7 at ON, 8 at ON 7 at OFF, 8 at OFF |

6.4 P4 Terminal

- When lights LD5 to LD8 turn on and the input signal fails, the microprocessor sets P4 as a conductive contact. P4 can be connected to an alarm or other similar devices for warning functions.

6.5 Sensitivity Switch Setting (SW2)

- When the value of sensitivity (%) is lower, the resolution of the input signal will be higher, and relatively the dead band will be smaller. Excessive high resolution may cause the actuator to keep hunting and could not run to the desired position. If this situation happens, it is suggested to adjust the sensitivity setting.
- Setting Range:

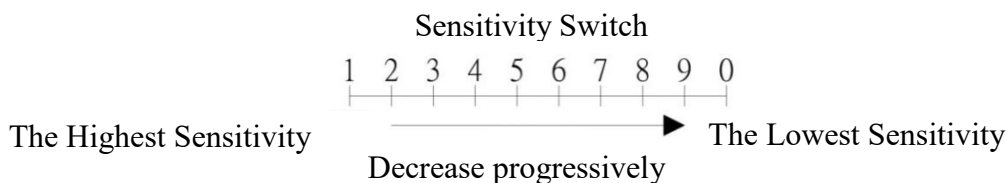

| | | | | | | | | | | |
|------------------------|------|-----|------|---|------|-----|------|---|------|-----|
| Setting Value | 1 | 2 | 3 | 4 | 5 | 6 | 7 | 8 | 9 | 0 |
| Sensitivity (%) | 0.25 | 0.5 | 0.75 | 1 | 1.25 | 1.5 | 1.75 | 2 | 2.25 | 2.5 |

- When set to 1, it means that the allowable tolerance is $\pm 0.25\%$, which is the highest sensitivity.
- When set to 0, it means that the allowable tolerance is $\pm 2.5\%$, which is the lowest sensitivity.
- For example, if the sensitivity switch is set to 3 and the target position is 50%, the valid travel range will be from 49.25% to 50.75% as shown in the figure below.



- Factory Default Setting:
 - S-500 to S-2600 : 3.

| Model | Figure |
|-----------------|---|
| S-500 to S-2600 |  |

6.6 Signal Settings for OPEN and CLOSE Position

- ⚠ **These settings are set and calibrated at the factory. Mostly, they do not need to be recalibrated. Please follow steps below to set when required.**
- ⚠ **Use a multimeter to measure the output signal in accordance with the selected signal type.**

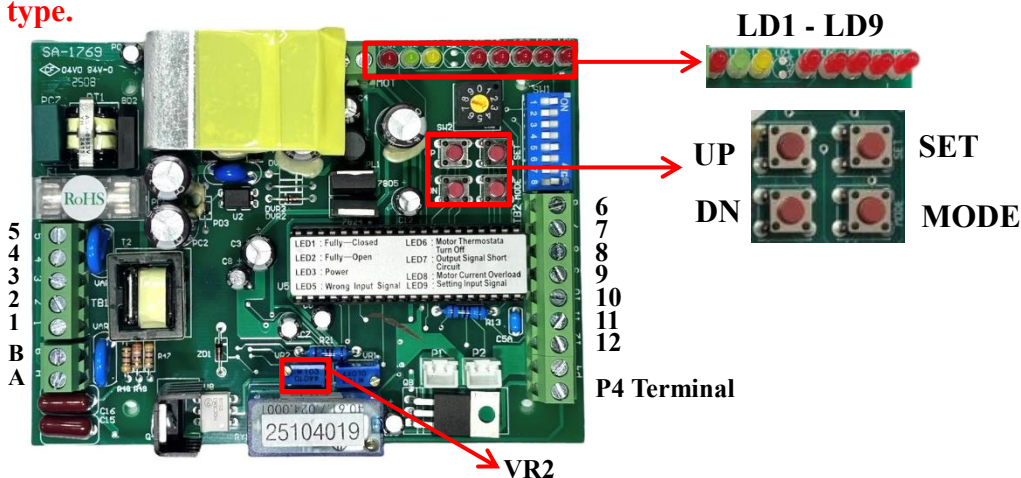

| Lamp | Status | Lamp | Status |
|------|---|------|-----------------------------------|
| LD1 | Fully-closed (Spring released) | LD6 | Motor thermal protector activated |
| LD2 | Fully-open (Spring compressed) | LD7 | Output signal short circuit |
| LD3 | Power | LD8 | Overcurrent in motor |
| LD5 | Wrong input signal | LD9 | Local setting mode |

Press and hold "SET" button for 2 seconds until LD 9 lights to enter local setting mode.

- **Signal setting for Fully-OPEN position (Spring compressed)**
 - a. Press and hold "UP" button to operate the actuator to open until it has reached the fully-open position and LD2 lights. Input the signal according the setting value of dip switch and check if output signal is correct, if not, correct output signal, adjust VR2 until you achieve the correct output signal.

VR2 Clockwise: increasing signal value.
 Counter-clockwise: decreasing signal value.

b. Press "MODE" button for 2 seconds to complete the setting of fully-open position.

- **Signal setting for Fully-CLOSED position (Spring released)**
 - a. Press and hold "DN" button to operate the actuator to close until it has reached fully-closed position and LD1 lights. Input the signal according the setting value of dip switch and check if output signal is correct, if not, correct output signal, adjust VR2 until you achieve the correct output signal.

VR2 Clockwise: increasing signal value.
 Counter-clockwise: decreasing signal value.

b. Press "MODE" button for 2 seconds to complete the setting of fully-closed position.

After completing the above settings, press "SET" switch to quit local setting.

6.7 Troubleshooting of modulating controller

- ⚠ In case LD3 does not light or any of LD5 to LD9 lights when the actuator is motorized, please refer to steps below for basic troubleshooting.**
- ⚠ Please do the troubleshooting when LD5 to LD9 lights, and then restart the power to turn the lights off.**

| Status of LEDs | Possible problems | Solution |
|--------------------|---|--|
| LD3 does not go on | <ul style="list-style-type: none"> a. No power supplied. b. Incorrect connection of the lines #8, #9 of the potentiometer c. Modulating controller failed. | <ul style="list-style-type: none"> a. Check the power supply as well as wires connected to terminals #4 & #5, please refer to 6 (P.23). b. Verify the actuator is wired properly as per wiring diagram. c. Send back to the factory for inspection. |
| LD5 goes on | <ul style="list-style-type: none"> a. An incorrect signal type inputted. For example, preset with 2 - 10 V input but input 4 - 20 mA. b. Input a voltage exceeding the rated. For example, preset with 2 - 10 V input but input 13.5 V. c. An incorrect signal type inputted. For example, preset with 4 - 20 mA input but input 2 - 10 V. In this case, the actuator still works in 2 - 7 V. When the signal is over 7.2 V, the LD5 lights. | <p>Verify if the switch 1 is set in accordance with the type of input signal. Please refer to 6.3 (P.24 to P.26).</p> |
| LD6 goes on | Motor thermal protector started. | <ul style="list-style-type: none"> a. The duty cycle exceeded the rated, please refer to 3.5 (P.5). b. The contact of the motor thermal protector (MOT) shall be wired in accordance with the wiring diagram. |
| LD7 goes on | <ul style="list-style-type: none"> a. Signal output short circuit. b. The input signal type 2 - 10 V with reversed polarity. | <ul style="list-style-type: none"> a. Verify if the signal output with reversed polarity. The negative pole should be connected to terminal #11 and the positive pole should be connected to terminal #12. b. Verify if the signal input with reversed polarity when applying 2 - 10 V, the negative pole should be connected to terminal #6 and the positive pole should be connected to terminal #7. |

【S Series】 Spring Return Fail-safe Electric Valve Actuators

| Status of LEDs | Possible problems | Solution |
|----------------|---|---|
| LD8 goes on | Motor over-current occurred, causing the motor lock up. | a. Duty cycle exceeded the rated. Please refer to 3.5 (P.5) and reduce the duty rating. b. Check the load. c. Check if the motor rotor is locked (For example: Valve is stuck by foreign objects). Confirm and solve the above issues, press and hold “MODE” button for 2 seconds to unlock the motor. |
| LD9 goes on | Local setting mode - Setting position for open & close. | After completing setting, press “SET” switch to quit. |

7 Troubleshooting

⚠ If the actuator selected with handwheel , after doing handwheel operation, be sure to use the handwheel to turn back to full-closed (spring released) position before input the power, it can be operating normally.

On / Off & Floating Control

Motor can not operate or overheats

| Possible problems | Solution |
|---|--|
| a. The seating torque of valve increased due to oxidized seals and has resulted in a torque overload on actuator. | a. Manually operate or replace the valve. |
| b. Jammed pipe or stuck valve seat. | b. Check if any blockage or obstacle in pipe and remove. |
| c. Motor shaft or bearing were stuck. | c. Replace them. |
| d. The limit switch for fully-closed does not trip (with manual override). | d. Operate the actuator manually to fully-closed position and confirm if the limit switch trips. |
| e. The limit switch for fully-closed does not trip (without manual override). | e. Check if a torque overload caused by the valve. |

The actuator functions normally but motor is hot.

| Possible problems | Solution |
|---|---|
| a. Actuator operates too frequently and exceeded duty cycle rating. | a. Adjust the system bandwidth or reduce the frequency of operation. |
| b. A torque overload caused by the valve. | b. This situation occurs frequently after the valve has been operating for a period of time. It is suggested to replace with a new valve. |
| c. Wrong power supply. | c. Check the power supply. |

The valve can not operate no matter under either electrical operation or manual operation.

| Possible problems | Solution |
|--|---|
| a. The actuator is not properly installed onto the valve. | a. Please refer to 4.2 (P.8). |
| b. The torque of valve is larger than the torque of actuator. | b. Replace with a new valve or a larger size actuator. |
| c. The cap screw of the cam loosened and resulted in that the travel end positions misaligned. | c. Readjust the mechanical end stops and limit switches, please refer to 4.5 (P.11 to P.18). |
| d. The OPEN and CLOSE end stop points of actuator are not aligned with valve. | d. Disassemble the actuator from the valve and reassemble them to ensure the OPEN and CLOSE stop points are aligned properly. |

【 S Series 】 Spring Return Fail-safe Electric Valve Actuators

The capacitor is faulty.

| Possible problems | Solution |
|---|---|
| The ambient temperature is too high or too low. | The actuator should be installed within the rated ambient temperature range of -30 °C to +65 °C (-22 °F to + 149 °F). |

Modulating Control

The LED indicators (LD5 - LD9) flash.

| Solution |
|----------------------|
| Refer to 6.7 (P.29). |

The LED indicators on the modulating board are normal, but the actuator cannot operate or can only operate in either the fully-open or fully-closed position.

| Possible problems | Solution |
|---|--|
| The signal input with a reversed polarity, it means a signal failure. | Verify if the negative pole of signal input connected to terminal #6 and the positive pole connected to terminal #7. |

Modulating control is not functioning

| Possible problems | Solution |
|--|--|
| <ul style="list-style-type: none"> a. The modulating board is faulty, and the actuator cannot operate or can only operate in one direction. b. Input wrong signal type. c. Modulating board failed and causes actuator can not operate or only operate in a single direction. | <ul style="list-style-type: none"> a. Replace a new modulating board b. Check if the input signal is correct, please refer to 6 (P.23 to P.30). c. Replace a new modulating board |

Spring cannot release to the right position in fully-open.

| Possible problems | Solution |
|---|---|
| <ul style="list-style-type: none"> a. The spring could not release properly. | <ul style="list-style-type: none"> a. Disassemble the actuator from the valve or damper and check if the spring can release successfully. If yes, it might be caused by abnormal torque from the valve or damper. If not, please contact your salesperson for further diagnostics. |

8 Actuator Options









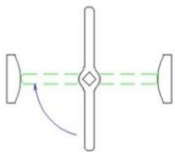

Fail clockwise (CW) rotation

When energized, the driven valve rotates CCW (viewed from the top of the actuator). Meanwhile, the springs are compressed. On loss of power, the spring returns (released) and the driven valve rotates CW.

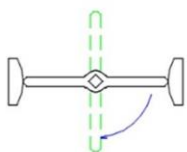

Fail counter-clockwise (CCW) rotation

When energized, the driven valve rotates CW (viewed from the top of the actuator). Meanwhile, the springs are compressed. On loss of power, the spring returns (released) and the driven valve rotates CCW.

| Valve operating direction | Desired fail position upon loss of supply voltage | Actuator Type | Handwheel direction |
|---|---|---------------|--|
| CW rotation for CLOSE  | Valve at fully-closed | CW | Direct mount per original factory setting.  |
| | Valve at fully-open | CCW | Adjust the tag and position indicator.  →  |
| CW rotation for OPEN  | Valve at fully-closed | CCW | Direct mount per original factory setting.  |
| | Valve at fully-open | CW | Adjust the tag and position indicator.  →  |

⚠ If the manual override is optioned, be sure to rotate the handwheel to run the actuator to fully-closed or fully-open position (spring released) after completing the handwheel operation, and ensure that the manual device indication is within the green zone for normal electrical operation.

Instructions for adjusting the open/close indicator beacon:

1. Loosen the lock screws of top cover (Figure 1).
2. After loosening the lock screws of the position indicator, remove the indicator from the top of the shaft. Rotate the indicator 90 degrees and lock the screws, then re-install the indicator scale (Figure 2).

The tag of CLOSE direction with an arrow pointing on the handwheel is printed on both of the sides A and B as Figure 4. Please adjust its direction in accordance with the configuration.

1. Loosen the screws of tag and adjust the tag to reflect the correct CLOSE direction (Figure 3).
2. Adjust the tag to side B (counter-clockwise in the closing direction) and tighten the screws (Figure 4).

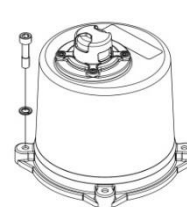

【Figure 1】



【Figure 2】



【Figure 3】

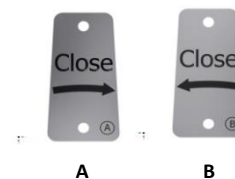

【Figure 4】

9 Warranty

Sun Yeh Ele. Co. Ltd. warrants that for a period of twelve months from the date of manufacture it will either repair or replace, at its option, any of its products which prove to be defective in material or workmanship. This warranty does not cover damage resulting from causes such as abuse, misuse, modification or tampering by users. This warranty is extended only to the immediate purchaser of the Sun Yeh product and is not transferable. To obtain service under this warranty, the purchaser must first acquire a return authorization from Sun Yeh. Products must be returned to Sun Yeh under freight prepaid.

This warranty is in lieu of all other obligations, liabilities or expressed warranties. Any implied warranties, including any implied warranty of merchantability are hereby expressly excluded. In no event shall Sun Yeh be liable for special, incidental or consequential damages arising in connection with the use of its products, or for any delay in the performance of this warranty due to cause beyond its control.

10 Disposal

Please obey the local environment regulation for equipment scrapping.



SUN YEH ELECTRICAL IND. CO., LTD.

No.68, Ln. 854, Sec. 1, Shatian Rd., Dadu Dist.,
Taichung City 432, Taiwan
Tel: +886-4-26985666 Fax: +886-4-26983668
E-mail: service@sunyeh.com



www.sunyeh.com