

## CAUTION !



- Please ensure that the O-ring seal is in good condition prior to cover installation.
- Installation, maintenance and repair works must be performed by trained personnel.
- Do not use any tools to increase force on handwheel for operating as this may damage the actuator or valve.
- DO NOT APPLY POWER BEFORE the actuator fully spring returns.

## Installation Notices

- The standard spring return actuator rotates counter-clockwise with power (spring compressed) and rotates clockwise with spring released (fully-closed or fully-open) when power outage.
- Please read operation manual and wiring diagram carefully before installation.
- Verify that supply voltage is in accordance with the data on nameplate to prevent short circuit or electrical/electronic parts damage caused by incorrect power input.
- Turn power off before wiring or maintenance.
- Connect the ground wire to PE point inside the actuator.
- To avoid functional failure caused by static, do not touch any components on the PCBA with metal tools or bare hands.
- Do not parallel wire multiple actuators together without using an extra relay.
- Use suitable water-proof cable gland to ensure it fits the conduit entry size, diameter of the cable and the enclosure protection of the actuator when wiring. The water-proof cable gland must be tightened and flattened to the cable after wiring procedure and use original black water-proof plug to seal unused conduit entry and fasten the top cover of the actuator to prevent dust or water from entering the actuator. The red plastic dust-proof plug is not meant for long-term use. Replace it with suitable water-proof connector to ensure the enclosure protection rating.
- After manual operation, the actuator shall be returned to its spring released position by handwheel before electrical operation of the actuator.
- Actuator should be installed in an upright or horizontal position. Do not mount upside down or below a horizontal position.
- These units are not designed to operate in vacuum spaces or where an explosive atmosphere exists.
- Periodically inspect actuator enclosure to prevent dust from accumulating.
- Please obey the local environment regulation for equipment scrapping.

## Manual Device Installation and Indication Instruction

- Slide fixing screw through washers and handwheel and secure them to override shaft as shown in the figure below (figure 1).  
 ⚠ Turn off power when installing handwheel.
- Assembly completed as shown in the figure below (figure 2).

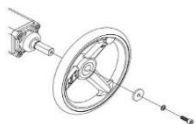

Figure 1



Figure 2

- Pointer Indication:  
 ⚠ If the actuator could not operate when supplying power, use the manual override to rotate the pointer to the green zone for normal operation.

Red Zone: Actuator can not operate normally when supplying power.  
 Green Zone: Actuator can operate normally when supplying power.

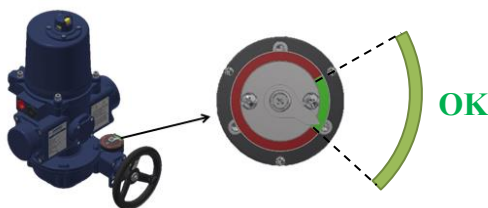

## Valve Mounting Instructions

⚠ For safety reasons, do not remove or inspect the SPRING STRUCTURE. Proper tools must be used, or serious injury will occur.

- The actuator shall be sized to ensure that its torque output meets the load requirements of valve. (As a MINIMUM, a 30% safety factor is suggested for the calculation of torque requirement).

If the maximum torque of 5" valve is 80 Nm  
 → 80 × 1.3 (safety factor) = 104 Nm  
**104 Nm < 130 Nm (S-1300) → OK!**  
 104 Nm > 50 Nm (S-500) → Not OK!

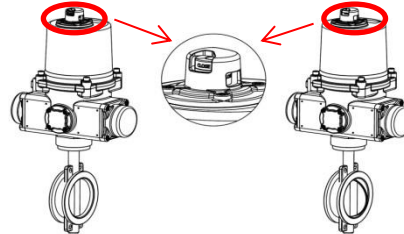

- The spring return actuator is shipped in spring return position (spring released) with the configuration of spring clockwise and fully-closed when power outage unless specified.
- The valve or damper must be rotated to fully-closed position before mounting with actuator if FAIL POSITION is fully-closed and vice versa.
- Remove all of valve handle parts, for example, the handle or open/close mechanical stops so as to not interfere with the actuator.  
 ⚠ Do not remove packing gland or other parts necessary for operation from valve.
- Check again that the valve and actuator are in the same position (fully-open or fully-closed).
- Once mounted together, either directly or with a mounting kit, ensure that they are properly secured together and all fasteners are tightened.
- Remove the conduit entry plug to relieve the pressure inside the actuator for the ease of the top cover removal and gently remove the cover.  
 ⚠ The power must be off before removing the cover.
- Refer to operation manual section 4.4 for wiring notices and connect the wires according to the wiring diagram labeled inside the cover of actuator.
- Supply power to actuator.  
 ⚠ Care must be taken at all times as there are live circuits present that may cause electrical shock.
- Re-calibration may be required for the end positions, refer to Actuator Set-up section for further instructions.
- Assemble the cover and secure cover screws firmly after setting.  
 ⚠ Please ensure that the O-ring seal is in good condition prior to cover installation.

## Actuator Set-up

- ⚠ If the actuator is equipped with a manual override, rotate the handwheel to return the actuator to its spring released position before the power is supplied.
- ⚠ Use proper cable glands with IP rating when installing and securely tighten the conduit fittings to ensure the enclosure protection rating.
- ⚠ DO NOT APPLY POWER BEFORE the actuator fully spring returns.

The spring return actuator provides fail-safe positioning and the end stop position of spring return is determined by either buffer or end stop (On/Off by the buffer, floating or modulating limited by end stop). When the actuator is motorized, the end position is determined by limit switches.

The actuator has been set and calibrated at the factory. Most of products will not require recalibration of these settings. However these are general settings. After valve and actuator are bolted together, apply power to drive the actuator to its fully-open (spring compressed). Then remove power to let the rack and pinion spring mechanism drive back to its fully-closed position. If the OPEN or CLOSE stop point are not aligned with valve or damper correctly, its end positions must be adjusted. Please follow steps below :

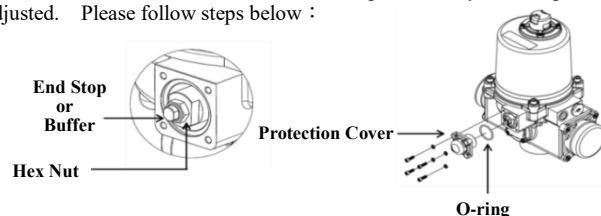

**▲ For modulating unit, ensure to loosen the sector gear of potentiometer first before adjusting the following settings.**

The actuator have been set and calibrated at the factory. After assembling and testing with valve or damper, if the fully-open and fully-closed positions of the actuator and the valve or damper are not aligned, please follow steps below to re-calibrate.

## Instructions - Fully-open and fully-closed position limit switches

- Actuators come standard with two limit switches, LS1 for fully-open and LS2 for fully-closed positioning. Two auxiliary limit switches (LS3 & LS4) are optional for fully-open and fully-closed position feedback. LS1 & LS2: LS1 is for fully-open and LS2 is for fully-closed. They limit the fully-open and fully-closed travel range by disabling the electric motor.
- LS3 & LS4 are optional. They allow external equipment to confirm that the valve has reached the fully-open and fully-closed positions.

The state of dry contact feedback signal :

- Solid line (—) : Dry contact in conductive state.
- Dotted line (---) : Dry contact in non-conductive state.

### 【S-500 to S-3600】

Symbol	Contact	Position	
		100%	0%
LS4 (Dry Contact)	D - F	-----	-----
	D - E	-----	-----
LS3 (Dry Contact)	A - C	-----	-----
	A - B	-----	-----

## Adjustment procedure for spring-return actuator in the fail-closed position upon loss of supply voltage.

### ● Adjust FULLY-CLOSED (spring released) stop point as steps below:

- Turn power off and loosen the protection cover using a 5 mm hex key.
- Adjust the hex nut, buffer or end stop.
  - S-500: Loosen the hex nut counterclockwise using a 22 mm open-end wrench, and adjust the buffer or end stop simultaneously using a 10 mm open-end wrench.
  - S-1300 to S-3600: Loosen the hex nut counterclockwise using a 32 mm open-end wrench, and adjust the buffer or end stop simultaneously using a 22 mm open-end wrench.
- Turn the buffer or end stop to adjust the fully-closed stop point.

Spring compressed 90°

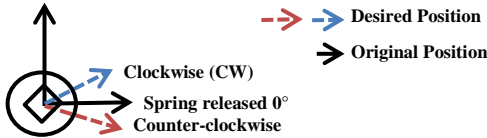

- S-500: One turn = 2.3 degrees.
- S-1300 to S-3600: One turn = 1.4 degrees.

- Once completed, tighten the hex nut, replace the protection cover and tighten all screws.

**▲ If the buffer or end stop is adjusted, TC2 must be reset in accordance with the buffer or the end stop.**

- Loosen the M3 cap screw of cam TC2 with a 2.5 mm hex key.
- Rotate the cam TC2 counter-clockwise until a light click is heard, and then slowly rotate the cam TC2 clockwise until a light click is heard, so that LS2 is not triggered.
- Tighten the cap screw of cam TC2.

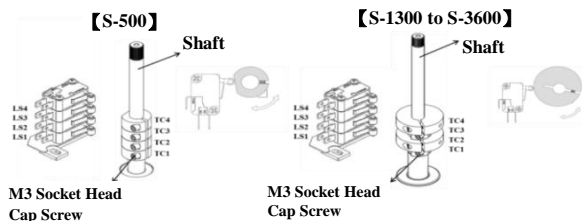

TC2 is utilized for sensing fully-closed stop point. Once the spring mechanism has been released when power outage, the actuator will not drive under power again until it has reached its fail stop position and TC2 trips.

TC1 "OPEN" Clockwise: increase opening degree.  
 Counter-clockwise: decrease opening degree.

Note:

- LS2 shall trip while TC2 reaches the end stop point.
- TC3 & TC4 are optional, refer to (f.) for calibration.

### ● Adjust FULLY-OPEN (spring compressed) stop point as steps below:

- Apply power to drive the actuator to its fully-open (spring compressed) position. If the open stop point is not aligned with the valve or damper properly, then it must be adjusted.
- Remove power to let spring system to drive back to its fully-closed (spring released) position.
- If it is required to adjust, loosen the cap screw of cam TC1 with a 2.5 mm hex key.
  - To increase the opening angle, turn the cam clockwise.
  - To decrease the opening angle, turn the cam counter-clockwise.

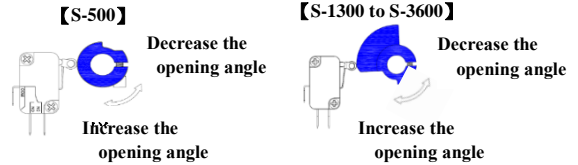

- After adjusting the cam, apply power to drive the actuator to the fully-open position.
- Verify that it is in the correct fully-open position.
  - If it is in correct position, remove power and lock the cap screw of cam TC1.
  - If it is not in correct position, repeat step C until the correct position is reached.
- If auxiliary switches will be used for feedback, cams TC3 and TC4 need to be calibrated.
  - Adjust cam TC3 so it trips just before cam TC1 does.
  - Adjust cam TC4 so it trips just before cam TC2 does.

- For modulating actuators, after completing the calibration, turn the actuator to fully-closed (spring released) position and follow the procedure below:

### Fail clockwise (CW) rotation

- Loosen M5 set screw.
- Rotate sector gear clockwise to the position shown in figure below.
  - ▲ Ensure that round gear and sector gear are engaged properly.**
- Tighten M5 set screw.

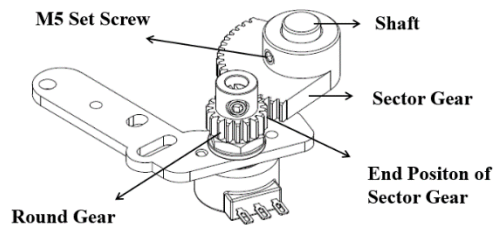

### Fail counter-clockwise (CCW) rotation

- Loosen M5 set screw.
- Rotate sector gear counter-clockwise to the position shown in figure below.
  - ▲ Ensure that round gear and sector gear are engaged properly.**
- Tighten M5 set screw.

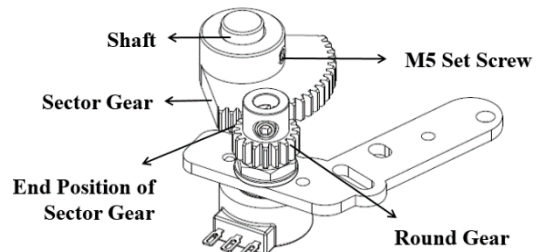

## Modulating Control Board Adjustment

▲ The layout is based on 110 / 220 V.

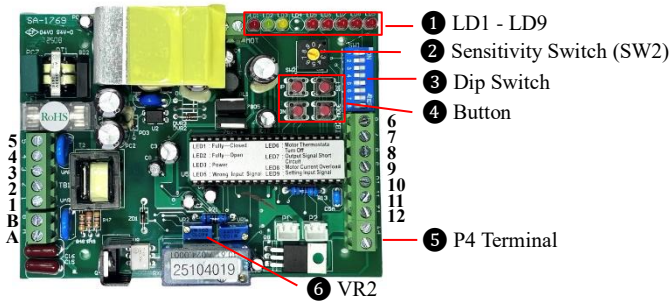

## Dip-Switch Setting

Factory Default Setting : 1, 4, 8 ON



\* S1, S2 : Input Signal Setting

\* S3, S4 & S5 : Output Signal Setting

Input Signal	S1	S2
4 - 20 mA	ON	OFF
1 - 5 V	OFF	OFF
2 - 10 V	OFF	ON

Output Signal	S3	S4	S5
4 - 20 mA	OFF	ON	OFF
2 - 10 V	ON	OFF	ON

\* S6 : Close direction setting

- When S6 is set to OFF, the close direction of output drive is CW (clockwise).
- When S6 is set to ON, the close direction output drive is CCW (counter-clockwise).

⚠ The input signal type is set by switches 1 and 2. And switch 6 is used to set the corresponding relationship between value of input signal and operation direction of actuator as shown in the figure below, e.g., 4 - 20 mA input signal.

⚠ The operating direction of the actuator has been set and calibrated at the factory. Be sure to change the direction of the position indicator if different operating direction is required.

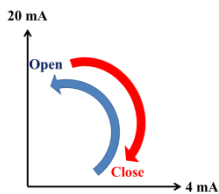

S6	Position Indicator (Fully-Open → Fully-Closed)	Operating Position	Input Signal	LED	Output Signal
OFF	CW	Fully-Closed	1 V, 2 V, 4 mA	LD1 ON	2 V, 4 mA
		Fully-Open	5 V, 10 V, 20 mA	LD2 ON	10 V, 20 mA

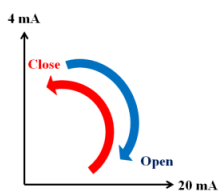

S6	Position Indicator (Fully-Open → Fully-Closed)	Operating Position	Input Signal	LED	Output Signal
ON	CCW	Fully-Closed	1 V, 2 V, 4 mA	LD1 ON	2 V, 4 mA
		Fully-Open	5 V, 10 V, 20 mA	LD2 ON	10 V, 20 mA

## P4 Terminal

- When the lights LD 5 to LD 8 light up and input signal failed, then the microprocessor conducts P4. It can connect with an alarm or similar devices for warning.

\* S7 & S8 : Setting of fail position when input signal failed.

Signal Failed Position	S7	S8
Fully-Open	ON	OFF
Fully-Closed	OFF	ON
The Last Position	ON	ON
	OFF	OFF

## Sensitivity Switch Setting (SW2)

When the value of sensitivity (%) is lower, the resolution of the input signal will be higher, and relatively the dead band will be smaller. Excessive high resolution may cause the actuator to keep hunting and could not run to the desired position. If this situation happens, it is suggested to adjust the sensitivity setting.

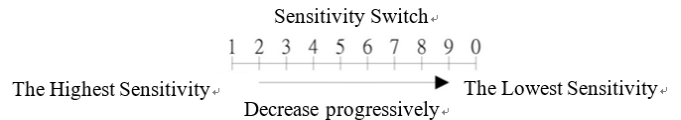

Setting Value	1	2	3	4	5	6	7	8	9	0
Sensitivity (%)	0.25	0.5	0.75	1	1.25	1.5	1.75	2	2.25	2.5

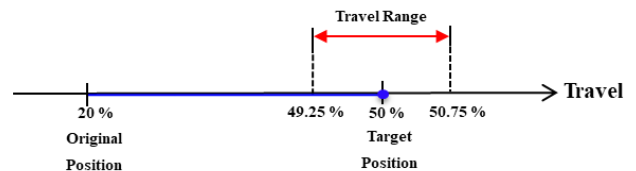

- When set to 1, it means that the allowable tolerance is  $\pm 0.25\%$ , which is the highest sensitivity.
- When set to 0, it means that the allowable tolerance is  $\pm 2.5\%$ , which is the lowest sensitivity.
- For example, if the sensitivity switch is set to 3 and the target position is 50%, the valid sensitivity range will be from 49.25% to 50.75% as shown in the figure below.
- Factory Default Setting: S-500 to S-2600 : 3.



## Signal Setting for Open and Close position

- ⚠ These settings are set and calibrated at the factory. Mostly, they do not need to be recalibrated. Please follow steps below to set when required.
- ⚠ Use a multimeter to measure the output signal in accordance with the selected signal type.

Lamp	Status	Lamp	Status
LD1	Fully-closed (Spring released)	LD6	Motor thermal protector activated
LD2	Fully-open (Spring compressed)	LD7	Output signal short circuit
LD3	Power	LD8	Overcurrent in motor
LD5	Wrong input signal	LD9	Local setting mode

Press and hold "SET" button for 2 seconds until LD 9 lights to enter local setting mode.

- ⓘ Please adjust the signal setting for fully-open position first, then adjust the signal setting for fully-closed position.

### Signal setting for Fully-OPEN position

- Press and hold "UP" button to operate the actuator to open until it has reached the fully-open position and LD2 lights and then input a signal 5 V or 10 V or 20 mA.
- Press "MODE" button for 2 seconds to complete the setting of fully-open position.

### Signal setting for Fully-CLOSED position

- Press and hold "DN" button to operate the actuator to close until it has reached fully-closed position and LD1 lights, and then input a signal 1 V or 2 V or 4 mA.
- Press "MODE" button for 2 seconds to complete the setting of fully-closed position.

After completing the above settings, press "SET" button to quit local setting.