



SE
SERIES
**Explosion-proof
Spring Return Fail-safe**
Electric Valve Actuators

SUNYEH

OPERATION MANUAL



SUN YEH ELECTRICAL IND. CO., LTD.

SY08-CA02A1-EN

Contents

1	General Information	1
1.1	Safety Instructions	1
1.2	Installation Notices	1
1.3	Working Conditions.....	4
1.4	Standards.....	4
1.5	Inspection, Storage, Transport	6
2	Product Overview	7
2.1	Features.....	8
3	Product Mechanical Data.....	9
3.1	Parts Identification.....	9
3.2	Technical Information.....	9
3.3	Mounting Base Details	10
3.4	Actuator Selection	10
3.5	Sizing	11
3.6	Duty Cycle – IEC.....	11
3.7	Flamepath Joint.....	12
3.8	Nameplate Details.....	13
4	Mounting And Setup.....	15
4.1	Manual Device Installation.....	15
4.2	Manual Device Indication Instruction	16
4.3	Valve Mounting Instructions.....	17
4.4	Wiring Instructions	18
4.5	Actuator Set-up.....	19
5	On / Off Control and Floating Control Board Adjustment	27
5.1	On / Off Control Board Surface.....	27
5.2	Troubleshooting of On / Off Controller	28
5.3	Floating Control Board Surface.....	29
5.4	Troubleshooting of Floating Controller	30
6	Modulating Control Board Adjustment	32
6.1	Modulating Control Board Surface	32
6.2	Programming	32
6.3	Dip Switch Setting (SW1)	33
6.4	P4 Terminal.....	35
6.5	Sensitivity Switch Setting (SW2)	36
6.6	Signal Settings for OPEN and CLOSE Position.....	37
6.7	Troubleshooting of Modulating Control.....	38
7	Troubleshooting.....	39
8	Actuator Options.....	42
9	Warranty	43
10	Disposal	43

1 General Information

⚠ Failure to follow safety instructions may cause serious injury, equipment damage, or voided warranty.

1.1 Safety Instructions

- Installation, maintenance and repair works must be performed by trained personnel.
- The handling shall follow the safety and warning instruction contained in this manual.
- Before operation, the user should read and follow instructions contained in this operation manual. Failure to do this may result in damages and void warranty. Sun Yeh will not be liable for damages due to operator negligence or misuse.
- Local health and safety legislation shall be complied with.
- In a few cases, the surface temperature may exceed 60 °C (140 °F). Please check the surface temperature before operation, using an appropriate thermometer and wearing protective gloves before operation.

1.2 Installation Notices

⚠ Operating by handwheel: Do not use any tools to increase force on handwheel for operating as this may damage the actuator or valve.

⚠ DO NOT APPLY POWER BEFORE the actuator fully spring returns.

1.2.1 General

- The standard spring return actuator rotates counter-clockwise with power (spring compressed) and rotates clockwise with spring released (fully-closed or fully-open) when power outage.
- DO NOT install in ambient temperatures that exceed 70 °C (158 °F).
- DO NOT, under any circumstances, remove the cover of the actuator while in a hazardous location when the power is still live inside the actuator. This could cause ignition of a hazardous atmosphere.
- DO NOT, under any circumstances, use an explosion-proof electric actuator in a hazardous location that does not meet the specification which the actuator was designed for.
- Mount, test, and calibrate actuators in non-hazardous location.
- When removing the actuator, care must be taken not to scratch, scar or deform the flame path of the cover or base of the actuator. That will negate the protection rating of the enclosure in a hazardous location.
- The explosion-proof electric actuator is shipped with mating surfaces of the cover and base. When assembling them, pay attention to the mating number (QA code) to assure the protection rating in a hazardous location.
- Please read operation manual and wiring diagram carefully before installation.

- Verify that supply voltage is in accordance with the data on nameplate to prevent short circuit or electrical/electronic parts damage caused by incorrect power input.
- Turn power off before wiring or maintenance.
- There are grounding devices both inside and outside of the actuator and the ground wires should be connected properly.
- The metal plugs in conduit entries are for transit only. For long term protection fit suitable flameproof cable gland and power cable should be with a minimum withstand temperature 105 °C (221°F). Please refer to 1.2.3 (P.3).
- To avoid functional failure caused by static, do not touch any components on the PCBA with metal tools or bare hands.
- Do not parallel wire multiple actuators together without using an extra relay.
- Use suitable explosion-proof and water-proof cable glands to ensure it fits the conduit entry size, diameter of the cable and the enclosure protection of the actuator when wiring. The explosion-proof and water-proof cable glands must be tightened and flattened to the cable after wiring procedure. Do not remove the explosion-proof and water-proof metal plugs from unused conduit entry, be sure to fasten the top cover of the actuator to reach explosion-proof and water-proof function.
- After manual operation, the actuator shall be returned to its spring released position by handwheel before electrical operation of the actuator.
- Actuator should be installed in an upright or horizontal position. Do not mount upside down or below a horizontal position.
- Periodically inspect actuator enclosure to prevent dust from accumulating.
- Perform below inspections prior to installation. Not allowed to adopt if any item is unqualified.
 - ✓ Check the marking and certificate number to see if it conforms to the indicated application.
 - ✓ All the parts of the housing are assembled in the right manner and fastened.
⚠ USE FASTENERS WITH YIELD STRESS \geq 450MPa.
 - ✓ All the explosion-proof parts should be made without cracks or functional defects.

1.2.2 CSA Certification Considerations

- KEEP COVER TIGHT WHILE CIRCUITS ARE ALIVE.
⚠ AFTER DE-ENERGIZING, DELAY 10 MINUTES BEFORE OPENING THE COVER.
- SEAL REQUIRED WITHIN 18 INCHES (450 mm) OF ENCLOSURE (for Divisions only).
- SEAL REQUIRED WITHIN 2 INCHES (50 mm) OF ENCLOSURE (for Zones only).

1.2.3 Cable Glands

- ⚠ **Please select the relatively explosion-proof cable connector according to the product specifications.**
- **ATEX / UKEX / IECEx Certification:**
 - ✓ The actuator is delivered with two conduit entries plugged by metal plugs. Use cable glands with ATEX / UKEX / IECEx certification and in accordance with the technical characteristics required by Ex db h IIB Gb, Ex tb h IIIC Db. The electrical supply cable must be suitable for power rating and with a minimum withstand temperature 105 °C (221 °F).
- **TS Certification:**
 - ✓ The actuator is delivered with two conduit entries plugged by metal plugs. Use cable glands with TS certification and in accordance with the technical characteristics required by Ex db IIB Gb, Ex tb IIIC Db. The electrical supply cable must be suitable for power rating and with a minimum withstand temperature 105 °C (221 °F).
- **CNEEx / CCC Certification:**
 - ✓ The actuator is delivered with two conduit entries plugged by metal plugs. Use cable glands with CNEEx certification and in accordance with the technical characteristics required by CNEEx Ex db IIB T4 Gb, Ex tb IIIC T130 °C Db. The electrical supply cable must be suitable for power rating and with a minimum withstand temperature 105 °C (221 °F).
- **CSA Certification:**
 - ✓ The actuator is delivered with two conduit entries plugged by metal plugs. Use cable glands with CSA certification. The electrical supply cable must be suitable for power rating and with a minimum withstand temperature 105 °C (221 °F).

1.3 Working Conditions

- **ATEX / UKEX / IECEx / CNEEx / CCC / TS Certification :**
 - ✓ Atmospheric pressure : 80 - 110 kPa.
 - ✓ Ambient temperature : - 30 °C to + 70 °C (- 22 °F to + 158 °F).
 - ✓ Relative humidity : Not more than 95 % (+ 25 °C / 77 °F).
 - ✓ The actuator can operate normally within tolerated variation of ± 10% of rated supply voltage or ± 1% of rated frequency.

- **CSA Certification :**
 - ✓ Atmospheric pressure : 80 - 106 kPa.
 - ✓ Ambient temperature : -30 °C to +70 °C (-22 °F to +158 °F).
 - ✓ Air with normal oxygen content : 21 % (Volume).

1.4 Standards

- **ATEX European Hazardous Area :** EN60079-0, EN60079-1, EN60079-31,
EN ISO 80079-36, EN ISO 80079-3

Directive	Group	Ambient Temperature
ATEX II 2 GD	Ex db h IIB T4 Gb	- 30 °C to + 70 °C (- 22 °F to + 158 °F)
ATEX II 2 GD	Ex tb h IIIC T130 °C Db	- 30 °C to + 70 °C (- 22 °F to + 158 °F)
ATEX II 2 GD	Ex db IIB T4 Gb	- 30 °C to + 70 °C (- 22 °F to + 158 °F)
ATEX II 2 GD	Ex tb IIIC T130 °C Db	- 30 °C to + 70 °C (- 22 °F to + 158 °F)

- **UKEX Great Britain Hazardous Area  :** EN60079-0, EN60079-1, EN60079-31,
EN ISO 80079-36, EN ISO 80079-3

Directive	Group	Ambient Temperature
UKCA II 2 GD	Ex db h IIB T4 Gb	- 30 °C to + 70 °C (- 22 °F to + 158 °F)
UKCA II 2 GD	Ex tb h IIIC T130 °C Db	- 30 °C to + 70 °C (- 22 °F to + 158 °F)
UKCA II 2 GD	Ex db IIB T4 Gb	- 30 °C to + 70 °C (- 22 °F to + 158 °F)
UKCA II 2 GD	Ex tb IIIC T130 °C Db	- 30 °C to + 70 °C (- 22 °F to + 158 °F)

- **IECEx International Hazardous Area :** IEC 60079-0, IEC 60079-1, IEC60079-31,
ISO 80079-36, ISO 80079-3

Group	Ambient Temperature
Ex db h IIB T4 Gb	- 30 °C to + 70 °C (- 22 °F to + 158 °F)
Ex tb h IIIC T130 °C Db	- 30 °C to + 70 °C (- 22 °F to + 158 °F)
Ex db IB T4 Gb	- 30 °C to + 70 °C (- 22 °F to + 158 °F)
Ex tb IIIC T130 °C Db	- 30 °C to + 70 °C (- 22 °F to + 158 °F)

【SE Series】 Explosion-proof Spring Return Fail-safe Electric Valve Actuator

- **CSA North American Hazardous Area :**

- ✓ **Zone System :**

CAN/CSA-C22.2 No. 60079-0, CAN/CSA-C22.2 No. 60079-1, CAN/CSA-C22.2 No. 60079-31, ANSI/UL 60079-0, ANSI/UL 60079-1, ANSI/UL 60079-31

Code	Hazard Class	Permitted Zone	Type of Protection	Groups	Temp Classification	Ambient Temperature
AEx / Ex	I	1	db	IIB, IIA	T4	- 30 °C to + 70 °C (- 22 °F to + 158 °F)
AEx / Ex	II	21	tb	IIIC, IIIB, IIIA	T130°C	- 30 °C to + 70 °C (- 22 °F to + 158 °F)

- ✓ **Division System :**

CSA C22.2 No. 30-M1986, CSA C22.2 No. 25-17, FM 3600, FM 3615, FM 3616

Hazard Class	Permitted Division	Groups	Temp Classification	Ambient Temperature
I	1	C,D	T4	- 30 °C to + 70 °C (- 22 °F to + 158 °F)
II	1	E,F,G	T130°C	- 30 °C to + 70 °C (- 22 °F to + 158 °F)

- **CNEx / CCC Certification :** GB/T 3836.1, GB/T 3836.2, GB/T 3836.31

Group	Ambient Temperature
Ex db IIB T4 Gb	- 30 °C to + 70 °C (- 22 °F to + 158 °F)
Ex tb IIIC T130 °C Db	- 30 °C to + 70 °C (- 22 °F to + 158 °F)

- **TS Certification :** IEC 60079-0, IEC 60079-1, IEC60079-31

Group	Ambient Temperature
Ex db IIB T4 Gb	- 30 °C to + 70 °C (- 22 °F to + 158 °F)
Ex tb IIIC T130°C Db	- 30 °C to + 70 °C (- 22 °F to + 158 °F)

1.5 Inspection, Storage, Transport

1.5.1 Receiving / Inspection

- Carefully inspect the package for any damages resulting from shipping and report all damages to the freight carrier and seller.
- After unpacking the product and information packet, please keep the cartons and any packing materials in case of product return or replacement. Verify that the items listed in packing slip or in bill of lading are the same as what were ordered. If there is any discrepancy, please contact the seller.
- Verify that the technical data on nameplate is in accordance with what was ordered.

1.5.2 Storage

- The actuator should be stored in a dry area with relative humidity of less than 90 % and at temperature between -20 °C to + 40 °C (-4 °F to + 104 °F).
- The product shall be stored with suitable protection from corrosive substance that can damage the metal and insulating parts.
- The metal plugs for temporary protection should not be removed until the actuator is ready to be cabled. Use suitable flameproof cable glands to ensure IP rated protection when installing. Please refer to 1.2.3 (P.3).

1.5.3 Transport

- Attach ropes or hooks for the purpose of lifting by hoist only to housing and not to handwheel.
- Actuators packaged in cartons can stand up to land, sea, or air transportation.
- Packaged actuators shall avoid of violent impact and strong vibrations and be protected from rain or snow.

1.5.4 Lubrication

- The gear train has been sufficiently lubricated at the factory. No additional lubrication is required.

2 Product Overview

SE series explosion-proof spring return fail-safe actuators are structured as flame-proof and combustible dust-proof and offer torque ranges from 50 Nm to 260 Nm (445 in-lb to 2300 in-lb) and are designed for fail-safe positioning of valves or dampers upon loss of supply voltage, which include On / Off control, floating control and modulating control. A rack and pinion spring mechanism is used to position the controlled device to either fully OPEN or fully CLOSED position without any external power source. For On/Off type, a mechanical BUFFER is used at the end of the spring stroke to reduce the water hammer effects in pipes. A clutch-less manual override is optional to provide manual positioning of the controlled device.

- **ATEX / UKEX / IECEx Explosion-proof instructions:**



II 2 GD Ex db h IIB T4 Gb, Ex tb h IIIC T130°C Db IP68



II 2 GD Ex db IIB T4 Gb, Ex tb IIIC T130°C Db IP68

- ✓ SE series Explosion-proof Spring Return Fail-safe Electric Valve Actuator (referred as "actuator") is a control device for valves and can be used in the places, where is classified as Zone 1 or Zone 2, contained Group IIA and Group IIB gases, Zone 21 or Zone 22, contained the combustible dust atmosphere or the mixture circumstance with the explosive gas atmospheres and the combustible dust atmospheres. Temperature group T1 - T4.

- **Certificate Number:**

Sira14ATEX1307X

IECEx SIR14.0109X

CSAE 21UKEX1206X

- **CNEEx / CCC Explosion-proof instructions:**



II 2 GD Ex db IIB T4 Gb, Ex tb IIIC T130°C Db IP68

- ✓ SE series Explosion-proof Spring Return Fail-safe Electric Valve Actuator (referred as "actuator") is a control device for valves and can be used in the places, where is classified as Zone 1 or Zone 2, contained Group IIA and Group IIB gases, Zone 21 or Zone 22, contained the combustible dust atmosphere or the mixture circumstance with the explosive gas atmospheres and the combustible dust atmospheres. Temperature group T1 - T4.

- **Certificate Number:**

CNEEx24.2342X (CCC : 2020312307000189)

- **TS Explosion-proof instructions:**

 **II 2 GD Ex db IIB T4 Gb, Ex tb IIIC T130°C Db IP68**

- ✓ SE series Explosion-proof Spring Return Fail-safe Electric Valve Actuator (referred as "actuator") is a control device for valves and can be used in the places, where is classified as Zone 1 or Zone 2, contained Group IIA and Group IIB gases, Zone 21 or Zone 22, contained the combustible dust atmosphere or the mixture circumstance with the explosive gas atmospheres and the combustible dust atmospheres. Temperature group T1 - T4.

- **Certificate Number:**
(ITIR) 2018 No.07-00012X

- **CSA explosion-proof instructions :**

- ✓ **Division System** where is classified as North American Division 1 or Division 2 of hazardous location, contains Group C and Group D gases and temperature group T1 - T4; or contains one or several flammable dusts with minimum flaming point over 130 °C ; or include both above flammable gases and dusts.
- ✓ **Zone System** where is classified as North American Zone 1 or Zone 2 of hazardous location, contains Group IIA and Group IIB gases and temperature group T1 - T4 ; or in Zone 21 or Zone 22, contained one or several flammable dusts with the minimum flaming point over 130 °C ; or include both above flammable gases and dusts.

- **Certificate Number :** 70177249

2.1 Features

- Enclosure conforms to IP68 (7m / 72 hrs).
- Controls: On / Off, floating (optional), modulating (optional).
- Clutch-less manual override (optional).
- ISO 5211 mounting flange.
- Mechanical position indicator.
- Built-in motor thermal protection

3 Product Mechanical Data

3.1 Parts Identification

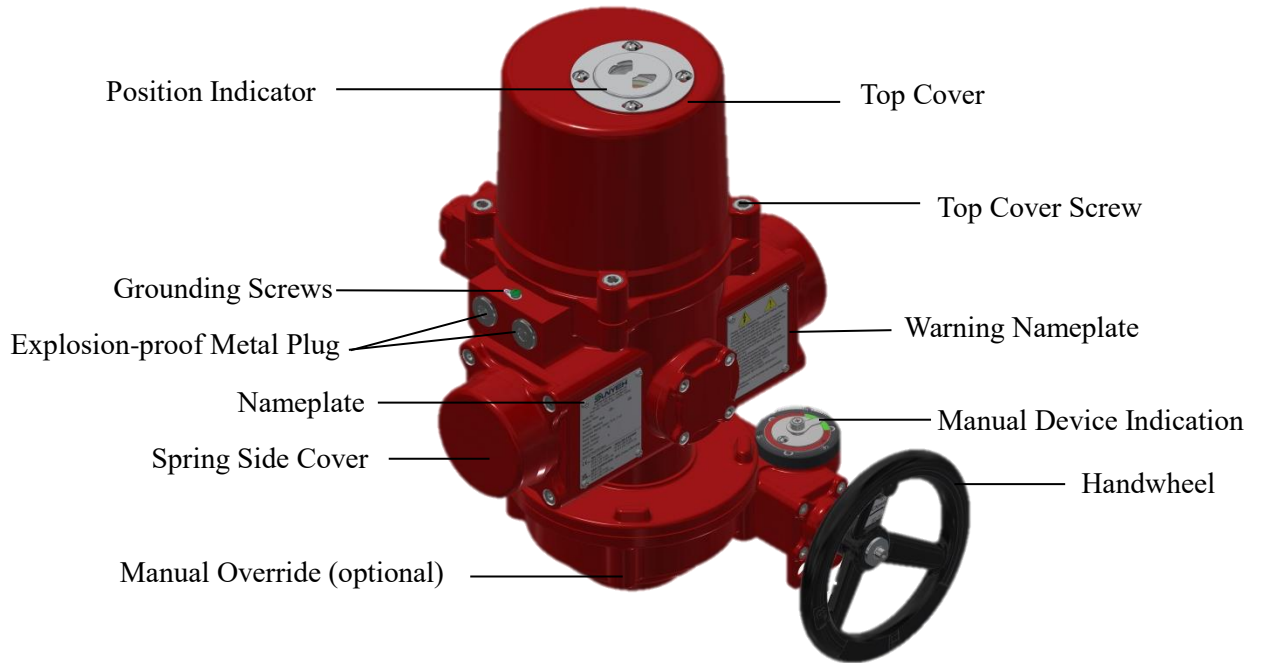

3.2 Technical Information

Model	Torque		Motor Power	Weight			
	Nm	in-lb		W	Standard		w/ Manual Override
			kg		lb	kg	lb
SE-500	50	445	50	28	62	38.5	85
SE-1300	130	1150	130	63	139	83	183
SE-2000	200	1770	130	96	212	135	298
SE-2600	260	2300	130	96	212	135	298

3.3 Mounting Base Details

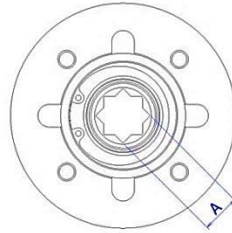
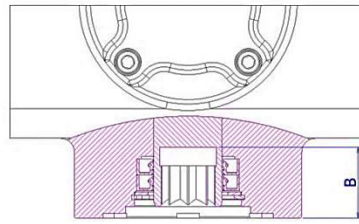

Model	Flange Type	Output Drive (A)		Depth of Output Drive (B)	
	ISO 5211	mm	inch	mm	inch
SE-500	F07	17	0.669	30	1.181
SE-1300	F10	22	0.866	41	1.614
SE-2000	F12	27	1.063	45	1.772
SE-2600	F12	27	1.063	45	1.772

3.4 Actuator Selection

SE-**1**-**2**-**3**-**4**-**5**

1 Type	2 Voltage	3 Direction of Rotation	4 Control Mode	5 Manual Override
500	24 : 24 V AC	CW : Fail Clockwise Spring Return.	T : On/Off.	Y : With Manual Override.
1300	D24 : 24 V DC		F : Floating.	N : Without Manual Override.
2000	120 : 110 - 120 V AC 1PH		M : Modulating.	
2600	220 : 220 - 240 V AC 1PH / 3PH 380 : 380 V AC 3PH 440 : 440 V AC 3PH	CCW : Fail Counter-Clockwise Spring Return.		

3.5 Sizing

 **For safety reasons, do not remove or inspect the SPRING STRUCTURE. Proper tools must be used, or serious injury will occur.**

The actuator shall be sized to ensure that its torque output meets the load requirements of valve. (As a MINIMUM, a 30% safety factor is suggested for the calculation of torque requirement).



- If the maximum torque of 5" valve is 80Nm → $80 \times 1.3 = 104 \text{ Nm}$
104 Nm < 130 Nm (SE-1300) → OK!
 104 Nm > 50 Nm (SE-500) → Not OK!

3.6 Duty Cycle – IEC

- The duty cycle is the relationship between the running time and resting time. It is calculated as below:

$$\text{Duty Cycle} = \frac{\text{Running Time (Sec)}}{\text{Running Time (Sec)} + \text{Rest Time (Sec)}} \times 100 \%$$

$$\Rightarrow \text{Rest Time (Sec)} = \frac{\text{Running Time (Sec)} \times (1 - \text{Duty Cycle})}{\text{Duty Cycle}}$$

- **If the motor running time is 10 sec, spring return time is 5 sec, 50% duty cycle, the rest (off) time shall be calculated as below:**
 - ✓ Running time: $[10 \text{ sec} \times (1 - 50 \%)] / 50 \% = 10$, rest time is 10 sec.
 - ✓ Spring return time : $[5 \text{ sec} \times (1 - 50 \%)] / 50 \% = 5$, rest time is 5 sec.
 -  **One cycle consists of open-rest-close-rest.**
 -  **A rest time is required after spring returned because the gear train and motor are driven during spring released.**

3.7 Flamepath Joint

- ⚠ **During cover removal and conduit entry removal, ensure that surfaces are free from scratches or scrapes.**
- ⚠ **Actuator installation and maintenance must be performed by trained personnel.**

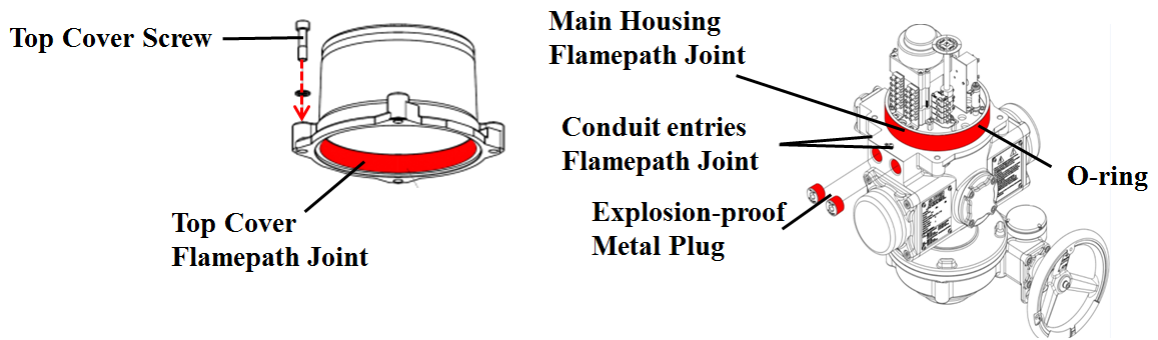

Cover Removal

Remove the conduit entry metal plugs to relieve the pressure inside the actuator for the ease of the top cover removal and gently remove the cover. **DO NOT** attempt to remove the top cover with a screwdriver as it will damage the surfaces.

Cover Installation

- ⚠ **Please ensure that the O-ring seal is in good condition prior to cover installation. Slowly re-install the cover while being careful not to pinch the O-ring seal.**
- ⚠ **The explosion-proof enclosures are labeled with a QA code on both of the middle plate and the cover, please verify the QA code inside the cover is the same as the one on middle plate when installation. The cover is not interchangeable.**

Please follow below table to tighten the top cover screws:

Model	Screw	Allen Key	Torque
		mm	Nm
SE-500	M10	8	43
SE-1300	M14	12	120
SE-2000 to SE-2600	M16	14	185

3.8 Nameplate Details

⚠ Please make sure the explosion-proof specification for the product is in consistence with nameplate and instruction.

SUNYEH
SUN YEH ELECTRICAL IND. CO., LTD.
No. 68, Ln. 854, Sec. 1, Shatian Rd.,
Dadu Dist., Taichung City, 432, Taiwan

- Model No.:
- Running Time: $\frac{\text{Sec. Motor}}{\text{Sec. Spring}}$
- Torque: N·m
- Fail-safe Direction:
- Enclosure Rating: IP68 (72 h, 7 m)
- Motor Power: W
- Supply Voltage:
- Rated Current: A
- Serial No.:
- Date of Manufacture:

CE 0470 **Sira 14ATEX1307X** **IECEX SIR 14.0109X**
 (E) II 2G Ex db h IIB T4 Gb Ex db h IIB T4 Gb
 (C) II 2D Ex tb h IIIC T130°C Db Ex tb h IIIC T130°C Db
UK CA 0518 **CSAE 21UKEX1206X**
 (E) II 2G Ex db h IIB T4 Gb -30°C ≤ Tamb ≤ +70°C
 (C) II 2D Ex tb h IIIC T130°C Db IP68

SUNYEH
SUN YEH ELECTRICAL IND. CO., LTD.
No. 68, Ln. 854, Sec. 1, Shatian Rd.,
Dadu Dist., Taichung City, 432, Taiwan

- Model No.:
- Running Time: $\frac{\text{Sec. Motor}}{\text{Sec. Spring}}$
- Torque: N·m
- Fail-safe Direction:
- Enclosure Rating: IP68 (72 h, 7 m)
- Motor Power: W
- Supply Voltage:
- Rated Current: A
- Serial No.:
- Date of Manufacture:

(TS) Ex db IIB T4 Gb
 Ex tb IIIC T130°C Db
 -30°C ≤ Tamb ≤ +70°C
 TD0404XY
 (ITRI)201807-00012X3R **CE** 0470

SUNYEH
SUN YEH ELECTRICAL IND. CO., LTD.
No. 68, Ln. 854, Sec. 1, Shatian Rd.,
Dadu Dist., Taichung City, 432, Taiwan

- Model No.:
- Running Time: $\frac{\text{Sec. Motor}}{\text{Sec. Spring}}$
- Torque: N·m
- Fail-safe Direction:
- Enclosure Rating: Type 4X
- Motor Power: W
- Supply Voltage:
- Rated Current: A
- Ambient Temp: - °C + °C
- Serial No.:
- Date of Manufacture:

Class I, Division 1, Groups C, D T4
 Class II, Division 1, Groups E, F, G T130°C
 Type 4X
 Ex db IIB T4 Gb (For Canada)
 Class I, Zone 1, AEx db IIB T4 Gb (For US)
 Ex tb IIIC T130°C Db (For Canada)
 Zone 21, AEx tb IIIC T130°C Db (For US)
 IP68 (72h, 7m)
 CSA 18.70177249X

- Please review Operation Manual and Wiring Diagram carefully before installation.
- For safety reasons, DO NOT remove or inspect the SPRING STRUCTURE under any circumstances.
- The metal plugs in conduit entries are for transit only. For long term protection, fit and tighten suitable flameproof and watertight cable glands. The withstand temperature of the cable shall not less 105°C (221°F).
- Units with hand wheel should be manually driven back to its failsafe position (springs released) before operating actuator electrically again.
- DO NOT OPEN WHEN ENERGIZED.
- AFTER ISOLATING POWER, DELAY 10 MINUTES BEFORE REMOVING COVER.
- USE FASTENERS WITH YIELD STRESS ≥ 450MPa.
- See instructions on how to avoid any electrostatic charging hazards.

- Please review Operation Manual and Wiring Diagram carefully before installation.
- For safety reasons, DO NOT remove or inspect the SPRING STRUCTURE under any circumstances.
- The metal plugs in conduit entries are for transit only. For long term protection, fit and tighten suitable flameproof and watertight cable glands. The withstand temperature of the cable shall not less 105°C (221°F).
- Units with hand wheel should be manually driven back to its failsafe position (springs released) before operating actuator electrically again.
- DO NOT OPEN WHEN ENERGIZED.
- AFTER ISOLATING POWER, DELAY 10 MINUTES BEFORE REMOVING COVER.
- USE FASTENERS WITH YIELD STRESS ≥ 450MPa.
- See instructions on how to avoid any electrostatic charging hazards.

- Please review Operation Manual and Wiring Diagram carefully before installation.
- For safety reasons, DO NOT remove or inspect the SPRING STRUCTURE under any circumstances.
- The metal plugs in conduit entries are for transit only. For long term protection, fit and tighten suitable flameproof and watertight cable glands. The withstand temperature of the cable shall not less 105°C (221°F).
- Units with hand wheel should be manually driven back to its failsafe position (springs released) before operating actuator electrically again.
- DO NOT OPEN WHEN ENERGIZED.
- CONDUIT SEAL WITHIN 18 INCHES (450mm) OF ENCLOSURE (For Division Classification only).
- CONDUIT SEAL WITHIN 2 INCHES (50 mm) OF ENCLOSURE (For Zone Classification only).
- AFTER ISOLATING POWER, DELAY 10 MINUTES BEFORE REMOVING COVER.
- USE FASTENERS WITH YIELD STRESS ≥ 450MPa.
- Veuillez lire attentivement le manuel d'utilisation et le schéma de câblage avant l'installation.
- Pour des raisons de sécurité, NE PAS enlever ni inspecter le MODULE DE RESSORTS en aucune circonstance.
- Les bouchons métalliques dans les entrées de conduits sont uniquement destinés au transit. Pour une protection à long terme, fixez et serrez les presse-étoupes appropriés, antidéflagrants et étanches. La température que peut supporter le câble ne doit pas être inférieure à 105°C (221°F).
- Les unités avec volant devraient être retrogradées à leur position par défaut (retour sur ressorts) avant de les alimenter à nouveau électriquement.
- NE PAS OUVRIR LORSQU'ALIMENTÉ.
- Sceau de conduit installé en-deçà de 450 mm de l'unité (Classification par Division uniquement).
- Sceau de conduit installé en-deçà de 50 mm de l'unité (Classification par Zone uniquement).
- TOUJOURS ATTENDRE 10 MINUTES APRÈS AVOIR COUPÉ L'ALIMENTATION AVANT D'OUVRIR LE COUVERCLE.
- N'utiliser que des attaches ayant une limite d'élasticité en traction ≥ 450MPa.

ATEX, UKEX & IECEx

TS

CSA

【SE Series】Explosion-proof Spring Return Fail-safe Electric Valve Actuator

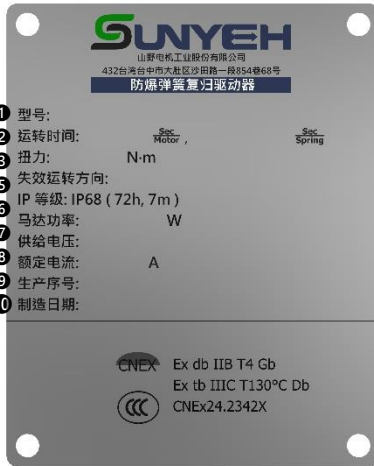

Nameplate Indication	
1 Model No.	7 Supply Voltage
2 Running Time	8 Rated Current
3 Torque	9 Serial No.
4 Fail-safe Direction	10 Date of Manufacture
5 Enclosure Rating	11 Ambient Temp
6 Motor Power	

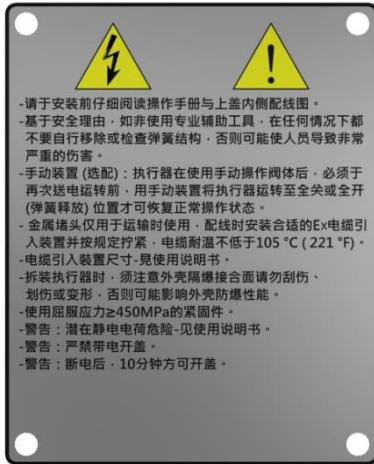

CCC & CNEX

4 Mounting And Setup

4.1 Manual Device Installation

- a. Slide fixing screw through washers and handwheel and secure them to override shaft as shown in the figure below.

⚠ Turn off power when installing handwheel.

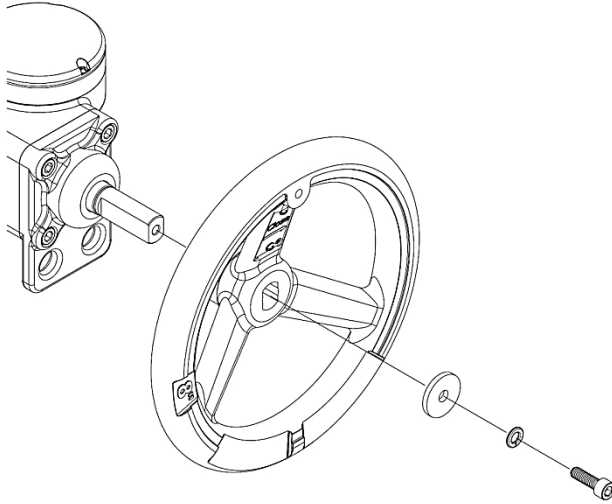

- b. Assembly completed as shown in the figure below.

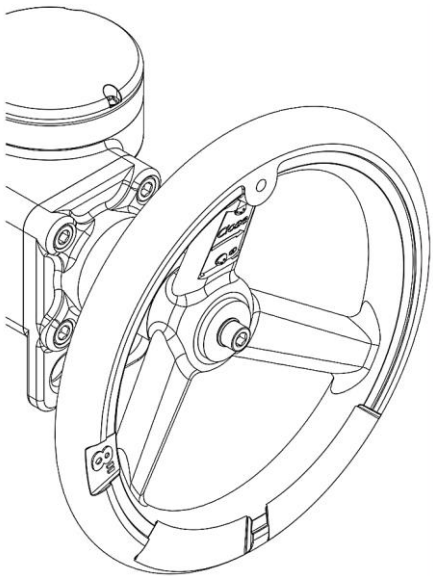

4.2 Manual Device Indication Instruction

- Pointer Indication:

⚠ If the actuator could not operate when supplying power, use the manual override to rotate the pointer to the green zone for normal operation.

Red Zone: Actuator can not operate normally when supplying power.

Green Zone: Actuator can operate normally when supplying power.

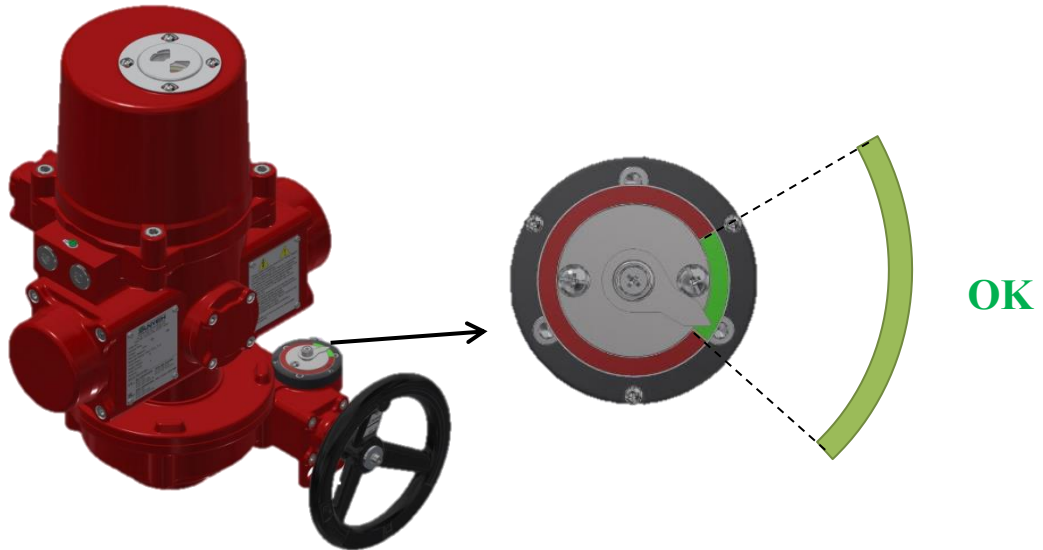

4.3 Valve Mounting Instructions

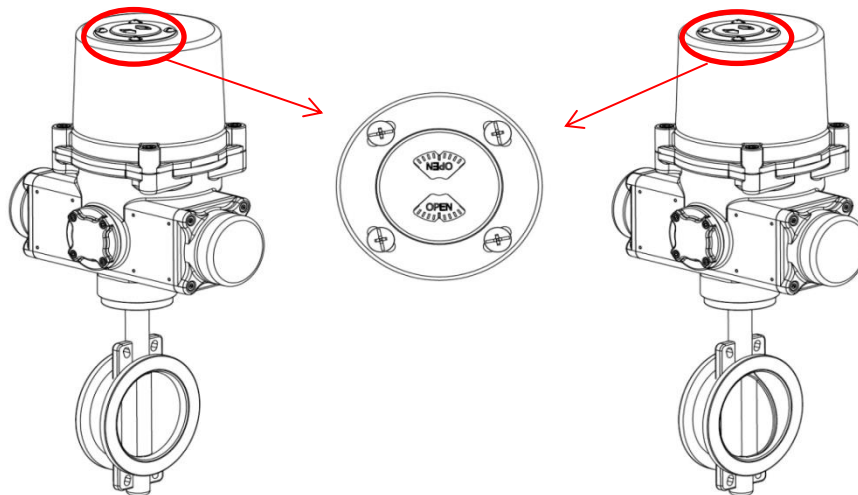

- a. The spring return actuator is shipped in spring return position (spring released) with the configuration of spring clockwise and fully-closed when power outage unless specified. Refer to section 8 to ensure actuator selected meets the application.
- b. Make sure the valve is in correct FAIL POSITION before mounting the actuator to it. Refer to illustration above.
- c. Remove all of valve handle parts, for example, the handle or open/close mechanical stops so as to not interfere with the actuator.
 - ⚠ **Do not remove packing gland or other parts necessary for operation from valve.**
- d. Check again that the valve and actuator are in the same position (fully-open or fully-closed).
- e. Once mounted together, either directly or with a mounting kit, ensure that they are properly secured together and all fasteners are tightened.
- f. Remove the conduit entry metal plugs to relieve the pressure inside the actuator for the ease of the top cover removal and gently remove the cover. Please refer to 3.7 (P.12) for cover installation.
 - ⚠ **The power must be off before removing the cover.**
 - ⚠ **AFTER DE-ENERGIZING, DELAY 10 MINUTES BEFORE OPENING THE COVER.**
- g. Refer to section 4.4 for wiring notices and connect the wires according to the wiring diagram labeled inside the cover of actuator.
- h. Supply power to actuator.
 - ⚠ **Care must be taken at all times as there are live circuits present that may cause electrical shock.**

- i. Re-calibration may be required for the end positions, refer to section 4.5 (P. 19) for further instructions.
- j. Assemble the cover and secure cover screws firmly after setting.
 - ⚠ Refer to 3.7 (P.12) for installation and check if there is any foreign object between top cover flamepath joint and base.**
 - ⚠ Please ensure that the O-ring seal is in good condition prior to cover installation.**
 - ⚠ The explosion-proof enclosures are labeled with a QA code on both of the middle plate and the cover, please verify the QA code inside the cover is the same as the one on middle plate when installation. The cover is not interchangeable.**

4.4 Wiring Instructions

- ⚠ Turn power off before making the electrical connection!**
- ⚠ Please remove the spacer (if applicable) before wiring and do not let any objects fall into the holes of the mounting plate.**

- There are grounding devices both inside and outside of the actuator (green screw) and the ground wires should be connected properly.
- The conduit entries are attached two conduit entries plugged by metal plugs, and the specification as below. Each actuator is attached with two metal plugs to conduit entries.
SE-500 to SE-2600: 1/2" NPT, 3/4" NPT, M20 x 1.5 or M25 x 1.5.
 - ⚠ Use correct size of fittings so as to not damage the threads.**
- Verify the supply power is in accordance with the data on the nameplate to prevent a short circuit and an electrical shock.
 - ⚠ Do not apply power to actuator before wiring, otherwise it can cause an electrical shock or damage components of the actuator.**
- After wiring, please tighten the conduit entries with suitable cable glands and cover properly. Unused conduit entries have to be sealed with metal plugs to reach explosion- proof function. Please refer to 1.2.2 - 1.2.3 (P.2).

4.5 Actuator Set-up

- ⚠ If the actuator is equipped with a manual override, rotate the handwheel to return the actuator to its spring released position before the power is supplied.**
- ⚠ Use proper cable glands with IP rating when installing and securely tighten the conduit fittings to ensure the enclosure protection rating.**
- ⚠ DO NOT APPLY POWER BEFORE the actuator fully spring returns.**

The spring return actuator provides fail-safe positioning and the end stop position of spring return is determined by either buffer or end stop (On / Off by the buffer, floating or modulating limited by end stop). When the actuator is motorized, the end position is determined by limit switches.

The actuator has been set and calibrated at the factory. Most of products will not require recalibration of these settings. However these are general settings. After valve and actuator are bolted together, apply power to drive the actuator to its fully-open (spring compressed). Then remove power to let the rack and pinion spring mechanism drive back to its fully-closed position. If the OPEN or CLOSE stop point are not aligned with valve or damper correctly, its end positions must be adjusted. Please follow steps below :

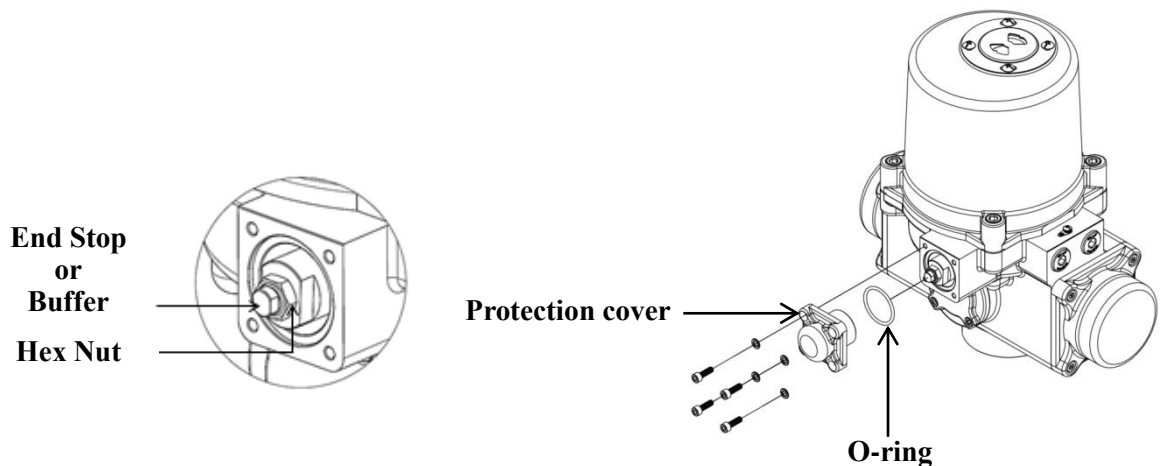

- ⚠ For modulating unit, ensure to loosen the sector gear of potentiometer first before adjusting the following settings.**

4.5.1 Adjustment procedure for spring-return actuator in the fail-closed position upon loss of supply voltage.

- **Adjust FULLY-CLOSED (spring released) stop point as steps below:**
 - a. Turn power off and loosen the protection cover using a 5 mm hex key.
 - b. Adjust the set hex nut, buffer or end stop.
 - SE-500: Loosen the hex nut counterclockwise using a 22 mm open-end wrench, and adjust the buffer or end stop simultaneously using a 10 mm open-end wrench.
 - SE-1300 to SE-2600: Loosen the hex nut counterclockwise using a 32 mm open-end wrench and adjust the buffer or end stop simultaneously using appropriate open-end wrench according to the control type below.
 - On / Off, Floating: 23 mm open-end wrench.
 - Modulating: 22 mm open-end wrench.
 - c. Turn the buffer or end stop to adjust the fully-closed stop point.

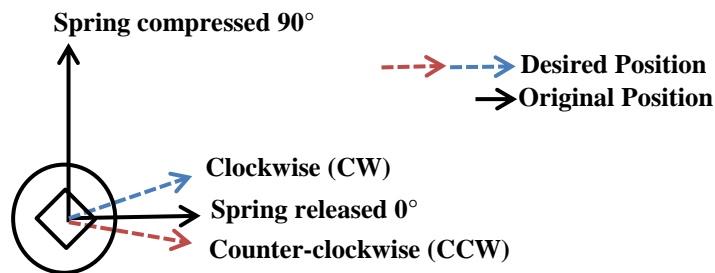

- SE-500 : One turn = 2.3 degrees
- SE-1300 to SE-2600 : One turn = 1.4 degrees.
- d. Once completed, tighten the hex nut, replace the protection cover and tighten all screws.
 - ⚠ **If the buffer or end stop is adjusted, TC2 must be reset in accordance with the buffer or the end stop.**
- e. Loosen the M3 cap screw of cam **TC2** with a 2.5 mm hex key..
- f. Rotate the cam **TC2** counter-clockwise until a light click is heard, and then slowly rotate the cam **TC2** clockwise until a light click is heard so that LS2 is not triggered.

【SE Series】Explosion-proof Spring Return Fail-safe Electric Valve Actuator

g. Tighten the cap screw of cam **TC2**.

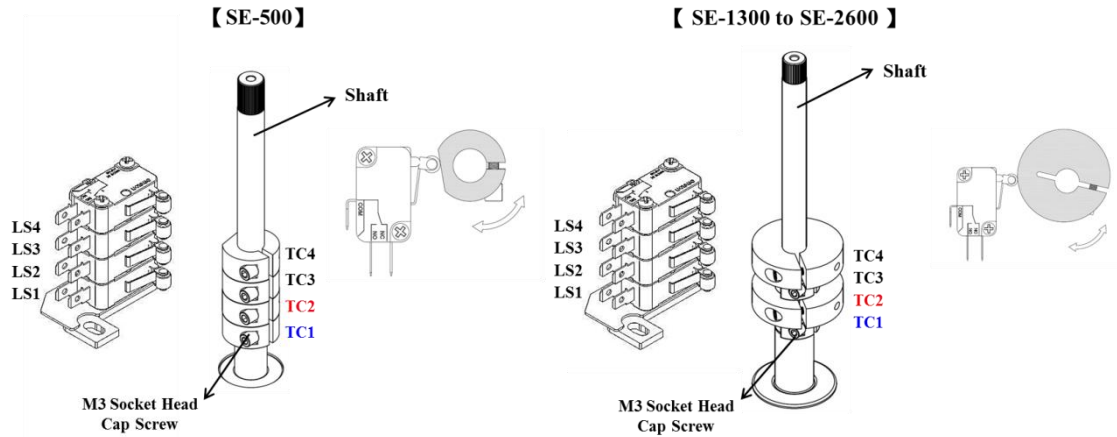

TC2 is utilized for sensing fully-closed stop point. Once the spring mechanism has been released when power outage, the actuator will not drive under power again until it has reached its fail stop position and **TC2** is not trigger LS2.

TC1 "OPEN" ↻ **Clockwise: increase opening degree.**
 ↻ **Counter-clockwise: decrease opening degree.**

Note:

- **LS2 shall trip while TC2 reaches the end stop point.**
- **TC3 & TC4 are optional, refer to P. 20 & P.23 section 2 (f.) and 4.5.2 (f.) for calibration.**

Dry contact sequence diagram (LS3 & LS4)

【SE-500 to SE-2600】

Symbol	Contact	Position	
		100%	0%
LS4 (Dry Contact)	D - F	-----●-----	-----●-----
	D - E	-----●-----	-----●-----
LS3 (Dry Contact)	A - C	-----●-----	-----●-----
	A - B	-----●-----	-----●-----

- Solid line (—) : Dry contact in conductive state.
- Dotted line (---) : Dry contact in non-conductive state.

- **Adjust FULLY-OPEN (spring compressed) stop point as steps below:**
 - a. Apply power to drive the actuator to its fully-open (spring compressed) position. If the open stop point is not aligned with the valve or damper properly, then it must be adjusted.
 - ⚠ **Do not remove the cover to supply power if the actuator is located in a hazardous environment. If so, please operate the unit manually.**
 - b. Remove power to let spring system to drive back to its fully-closed (spring released) position.
 - c. If it is required to adjust, loosen the cap screw of cam TC1 with a 2.5 mm hex key.
 - To increase the opening angle, turn the cam clockwise.
 - To decrease the opening angle, turn the cam counter-clockwise.

【SE-500】

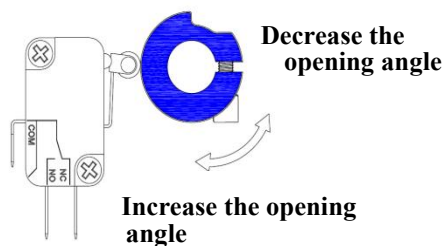

【SE-1300 to SE-2600】

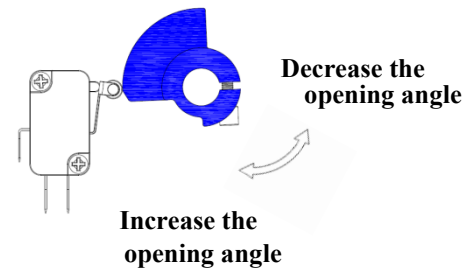

- d. After adjusting the cam, apply power to drive the actuator to the fully-open position.
- e. Verify that it is in the correct fully-open position.
 - ⚠ **Do not remove the cover to supply power if the actuator is located in a hazardous environment. If so, please operate the unit manually.**
 - If it is in correct position, remove power and lock the cap screw of cam TC1.
 - If it is not in correct position, repeat step C until the correct position is reached.
- f. If auxiliary switches will be used for feedback, cams TC3 and TC4 need to be calibrated.
 - Adjust cam TC3 so it trips just before cam TC1 does.
 - Adjust cam TC4 so it trips just before cam TC2 does.

4.5.2 Adjustment procedure for spring-return actuator in the fail-open position upon loss of supply voltage

- Adjust FULLY-OPEN (spring released) stop point as steps below:
 - a. Turn power off and loosen the protection cover using a 5 mm hex key.
 - b. Adjust the set hex nut, buffer or end stop.
 - SE-500: Loosen the hex nut counterclockwise using a 22 mm open-end wrench, and adjust the buffer or end stop simultaneously using a 10 mm open-end wrench.
 - SE-1300 to SE-3600: Loosen the hex nut counterclockwise using a 32 mm open-end wrench and adjust the buffer or end stop simultaneously using appropriate open-end wrench according to the control type below.
 - On / Off, Floating: 23 mm open-end wrench.
 - Modulating: 22 mm open-end wrench.
 - c. Turn the buffer or end stop to adjust the fully-open stop point.

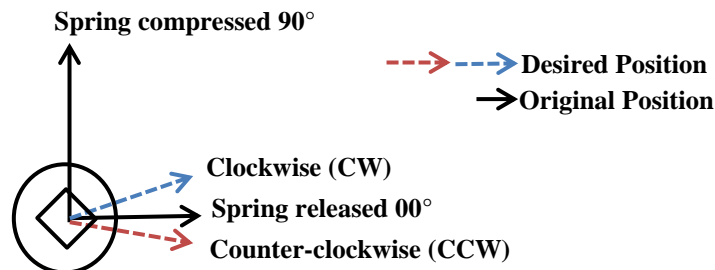



- SE-500 : One turn = 2.3 degrees
- SE-1300 to SE-2600 : One turn = 1.4 degrees
- d. Once completed, tighten the hex nut, replace the protection cover and tighten all screws.
 - ⚠ **If the buffer or end stop is adjusted, TC2 must be reset in accordance with the buffer or the end stop.**
- e. Loosen the M3 cap screw of cam **TC2** with a 2.5 mm hex key.
- f. Rotate the cam **TC2** counter-clockwise until a light click is heard and then slowly rotate the cam **TC2** clockwise until a light click is heard so that LS2 is not triggered.

【SE Series】Explosion-proof Spring Return Fail-safe Electric Valve Actuator

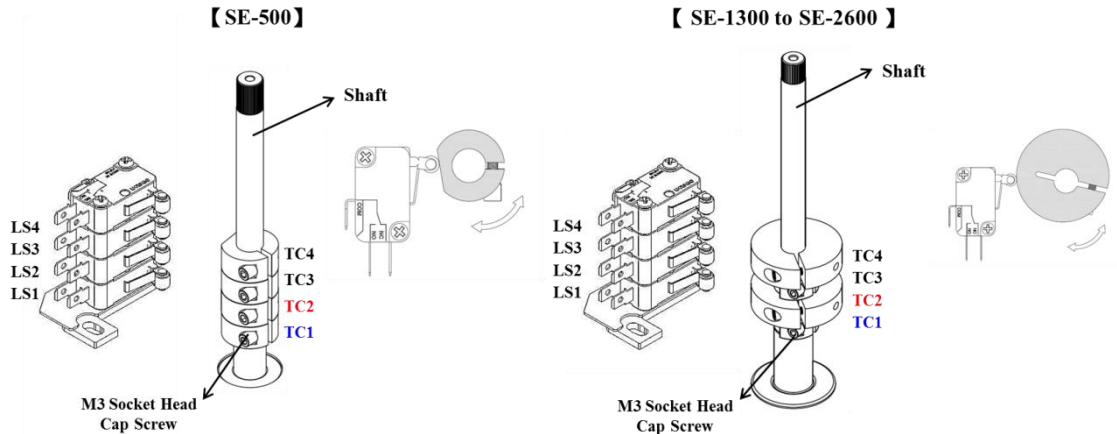
g. Tighten the cap screw of cam **TC2**.



TC2 is utilized for sensing fully-closed stop point. Once the spring mechanism has been released when power outage, the actuator will not drive under power again until it has reached its fail stop position and **TC2** is not trigger LS2.

TC1 "OPEN"  Clockwise: decrease closing degree.
 Counter-clockwise: increase closing degree.

Note:

- LS2 shall trip while **TC2** reaches the end stop point.
- TC3 & TC4 are optional, refer to P. 20 & P. 23 section 2 (f.) and 4.5.2 (f.) for calibration.

Dry contact sequence diagram (LS3 & LS4)

【SE-500 to SE-2600】

Symbol	Contact	Position	
		100%	0%
LS4 (Dry Contact)	D - F	-----	-----●-----
	D - E	-----	-----●-----
LS3 (Dry Contact)	A - C	-----●-----	-----
	A - B	-----●-----	-----

- Solid line (—) : Dry contact in conductive state.
- Dotted line (-----) : Dry contact in non-conductive state.

- **Adjust FULLY-CLOSED (spring compressed) stop point as steps below:**
 - a. Apply power to drive the actuator to its fully-closed (spring compressed) position. If the close stop point is not aligned with the valve or damper properly, then it must be adjusted.
 - ⚠ **Do not remove the cover to supply power if the actuator is located in a hazardous environment. If so, please operate the unit manually.**
 - b. Remove power to let spring system to drive back to its fully-open (spring released) position.
 - c. If it is required to adjust, loosen the cap screw of cam **TC1** with a 2.5 mm hex key.
 - To increase the closing angle, turn the cam clockwise.
 - To decrease the closing angle, turn the cam counter-clockwise.

【SE-500】

【SE-1300 to SE-2600】

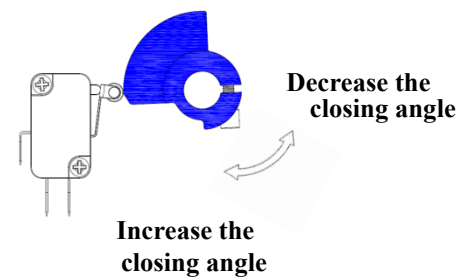
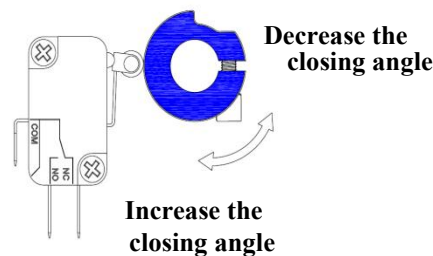

- d. After adjusting the cam, apply power to drive the actuator to the fully-closed position.
- e. Verify that it is in the correct fully-closed position.
 - ⚠ **Do not remove the cover to supply power if the actuator is located in a hazardous environment. If so, please operate the unit manually.**
 - If it is in correct position, remove power and lock the cap screw of cam **TC1**.
 - If it is not in correct position, repeat step C until the correct position is reached.
- f. If auxiliary switches will be used for feedback, cams TC3 and TC4 need to be calibrated.
 - Adjust cam TC3 so it trips just before cam **TC1** does.
 - Adjust cam TC4 so it trips just before cam **TC2** does.

4.5.3 Modulating Control Actuators Potentiometer Setting

- For modulating actuators, after completing the calibration, turn the actuator to fully-closed or fully-open position (spring released) and follow the procedure below:

Fail clockwise (CW) rotation

- Loosen M5 set screw.
- Rotate sector gear clockwise to the position shown in figure below.
 - ⚠ **Ensure round gear and sector gear are engaged properly.**
- Tighten M5 set screw.

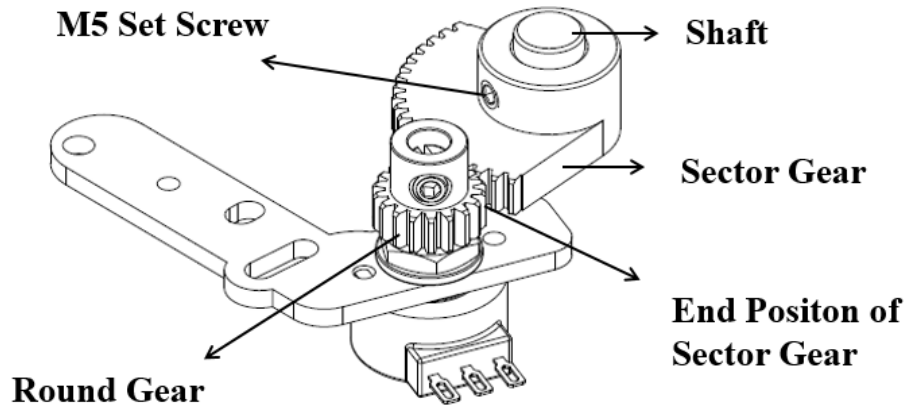

Fail counter-clockwise (CCW) rotation

- Loosen M5 set screw.
- Rotate sector gear counter-clockwise to the position shown in figure below.
 - ⚠ **Ensure that round gear and sector gear are engaged properly.**
- Tighten M5 set screw.

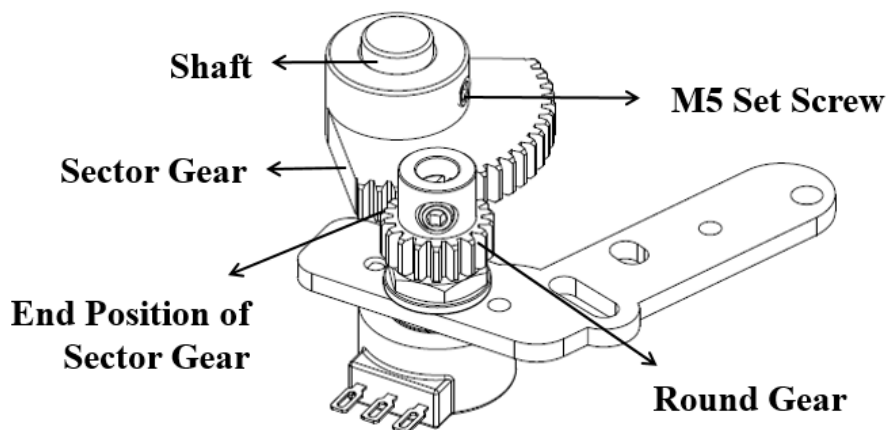

5 On / Off Control and Floating Control Board Adjustment

5.1 On / Off Control Board Surface

The layout is based on 110 / 220 V.

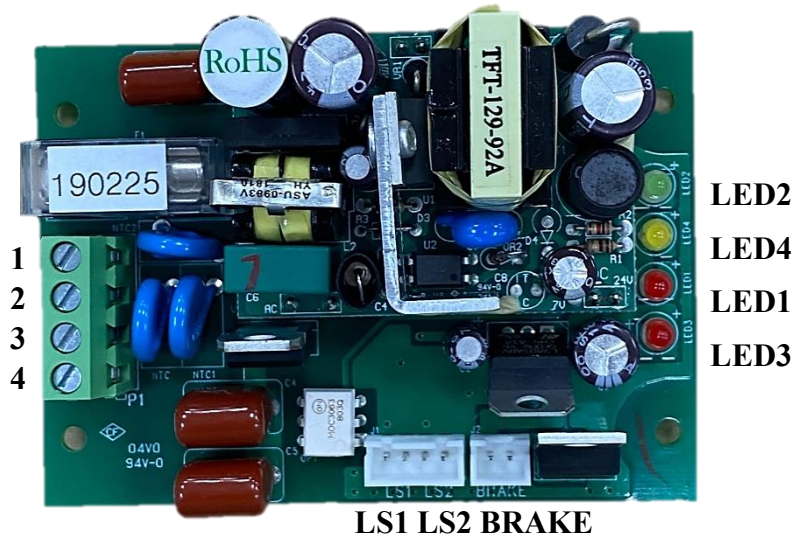

- Indicator Lamp

Lamp No.	Status
LED1	Power
LED2	Operating
LED3	Motor Brake
LED4	Alerting Signal

5.2 Troubleshooting of On / Off Controller

⚠ In case LED1 to LED3 does not light or LED4 lights when the actuators are motorized, please refer to steps below for basic troubleshooting.

Status of LEDs	Possible problems	Solution
LED4 goes on	<ul style="list-style-type: none"> a. LS1 and LS2 terminals loose or poor contact. b. Incorrect connection of the terminal LS1 or LS2. c. The input power failure time is more than 150ms. d. Abnormal setting of limit switches and cams. e. Supply the power again during spring released. f. LS1 and LS2 failed. g. Actuator overload cause it can not returned to spring released position and restart. h. Abnormal setting of cam TC and cause the contact of LS2 can not be released. 	<ul style="list-style-type: none"> a. Make sure to connect the PCBA terminals firmly. If it is damaged, please replace new terminals. b. Verify the actuator is wire properly as per wiring diagram. c. Please provide an independent power supply to actuator to avoid unstable power supply and cause the actuator enter to self-protection. d. Please refer to 4.5 (P.19 to P.26) Actuator set-up. e. Power off until the actuator return to spring released position and then supply power again. f. Replace new limit switches. g. Please refer to 3.5 (P.11) Sizing. h. Please refer to 4.5 (P.19 to P.26) Actuator set-up.
LED1 does not go on	<ul style="list-style-type: none"> a. Wrong supply voltage. b. Blown fuse. c. PCBA failed. 	<ul style="list-style-type: none"> a. Check the power supply is according to the actuator rated voltage. b. Replace a new fuse. c. Replace a new PCBA.
LED2 does not go on	<ul style="list-style-type: none"> a. Abnormal Setting for LS1 and LS2. b. PCBA failed. ° 	<ul style="list-style-type: none"> a. Check the LED 4, if the LED4 lights please refer to the troubleshooting for LED4. b. Replace a new PCBA.
LED3 does not go on	<ul style="list-style-type: none"> a. PCBA failed. 	<ul style="list-style-type: none"> a. Replace a new PCBA.

5.3 Floating Control Board Surface

The layout is based on 110 / 220 V.

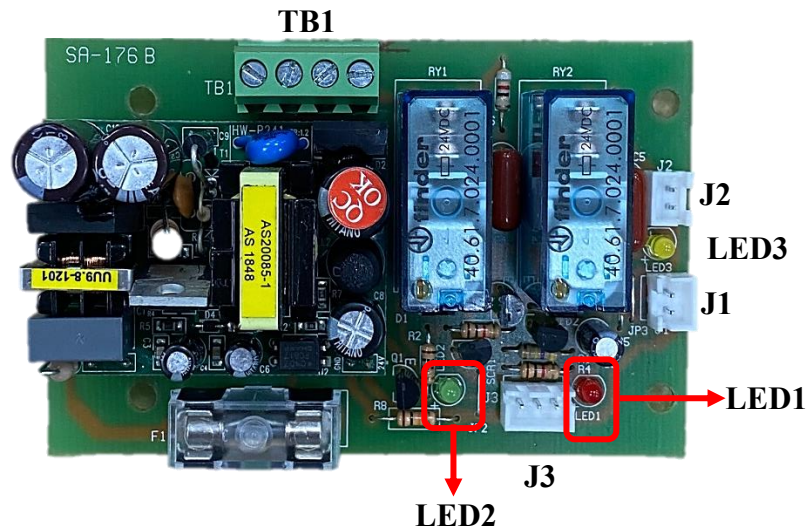

- Indicator Lamp

Lamp No.	Status
LED1	Spring Released
LED2	Spring Compressed
LED3	Power

5.4 Troubleshooting of Floating Controller

⚠ In case LED1 to LED3 does not light when the actuator is motorized, please refer to steps below for basic troubleshooting.

Status of LEDs	Possible problems	Solution
LED1 does not go on	<ul style="list-style-type: none"> a. Abnormal control signal. b. PCBA failed. c. Abnormal power supplied. d. The terminals loose or damaged. 	<ul style="list-style-type: none"> a. Check if the terminal #4 and #6 is conducted. b. Replace a new PCBA ◦ c. Check the power supply is according to the actuator rated voltage. d. Make sure to connect the PCBA terminals firmly. If the terminals are damaged, please replace the PCBA.
LED2 does not go on	<ul style="list-style-type: none"> a. Abnormal control signal. b. PCBA failed. c. Abnormal power supplied. d. The cam active the limit switch. e. Incorrect setting of the LS1 and TC1. f. Incorrect connection of LS1. g. The terminals loose or damaged. 	<ul style="list-style-type: none"> a. Check if the terminal #4 and #5 is conducted. b. Replace a new PCBA ◦ c. Check the power supply is according to the actuator rated voltage d. It's normal condition, please refer to 4.5 (P.19 to P.26) Actuator set-up if need to adjusted. e. Check if the LS1 is conducted when the actuator return to spring released position, if not please refer to 4.5 (P.19 to P.26) Actuator set-up. f. Verify the actuator is wire properly as per wiring diagram. g. Make sure to connect the PCBA terminals firmly. If the terminals are damaged, please replace the PCBA.

【SE Series】Explosion-proof Spring Return Fail-safe Electric Valve Actuator

Status of LEDs	Possible problems	Solution
LED3 does not go on	<ul style="list-style-type: none"> a. Abnormal power supply. b. Blown fuse (F1). c. PCBA failed. d. Incorrect setting of the LS2 and TC2. e. Actuator overload. f. Actuator is abnormal and can not return to spring released position. g. Incorrect connection of LS1. h. The terminals loose or damaged. 	<ul style="list-style-type: none"> a. Check the power supply is according to the actuator rated voltage. b. Replace a new fuse. c. Replace a new PCBA. d. Check if the LS2 is conducted when the actuator return to spring released position, if not please refer to 4.5 (P.19 to P.26) Actuator set-up. e. Check if the torque of valve larger than actuator rated torque. f. Contact with factory to replace new actuator. g. Verify the actuator is wire properly as per wiring diagram h. Make sure to connect the PCBA terminals firmly. If the terminals are damaged, please replace the PCBA.

6 Modulating Control Board Adjustment

6.1 Modulating Control Board Surface

The layout is based on 110 / 220 V.

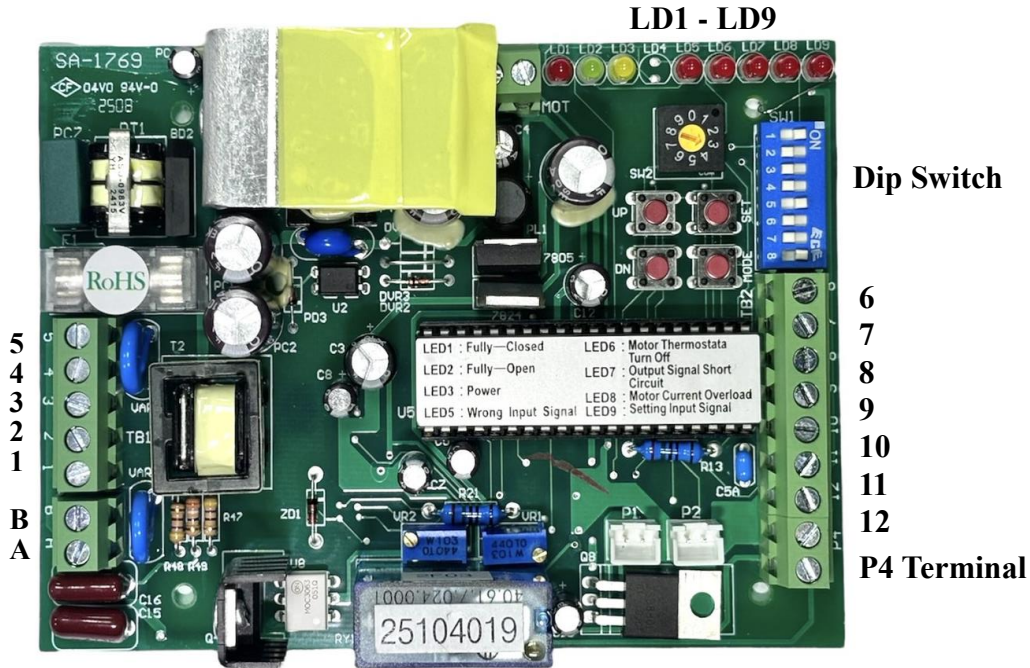

6.2 Programming

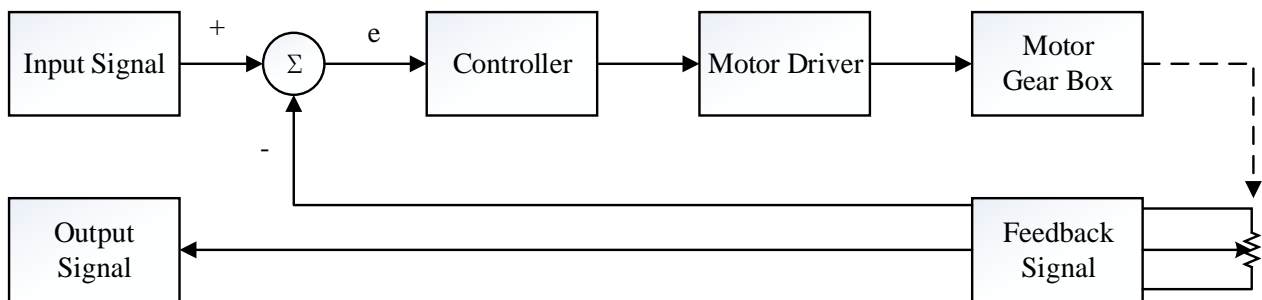

6.3 Dip Switch Setting (SW1)

The Dip Switch SW1 is a combination of 8 switches and equally divided in two rows. It is utilized to select signal type of input as well as output and fail positioning when the signal input fails. The sliders can be placed at either ON (upper) or OFF (lower) state position. Factory default settings are switches 1, 4, 8 at ON state and switches 2, 3, 5, 6, 7 at OFF state.



Please follow steps below if an adjustment of these settings are required.

⚠ Please restart the actuator after adjusting.

	1	2	3	4	5	6	7	8
Default Setting	ON	OFF	OFF	ON	OFF	OFF	OFF	ON
4 - 20 mA input	ON	OFF						
1 - 5 V input	OFF	OFF						
2 - 10 V input	OFF	ON						
4 - 20 mA output			OFF	ON	OFF			
2 - 10 V output			ON	OFF	ON			
Closing direction setting: CW						OFF		
Closing direction setting: CCW						ON		
When signal input failed, driving valve to fully-open.							ON	OFF
When signal input failed, driving valve to fully-closed.							OFF	ON
When signal input failed, valve stays at the last position.							ON	ON
							OFF	OFF

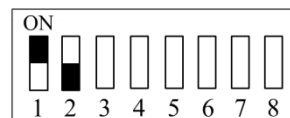

a. Input Signal Setting (switches 1 - 2)

Input Signal	State of Switches
4 - 20 mA	1 at ON, 2 at OFF
1 - 5 V	1 at OFF, 2 at OFF
2 - 10 V	1 at OFF, 2 at ON

【SE Series】 Explosion-proof Spring Return Fail-safe Electric Valve Actuator

b. Output Signal Setting (switches 3 - 5)

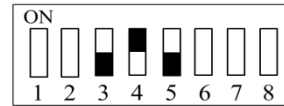

- Output signal can be fine-tuned by VR2.
- When resetting the Output Signal, be sure to fine-tune VR2 to match either the 2 - 10 V or 4 - 20 mA setting.

Output Signal	State of Switches
4 - 20 mA	3 at OFF, 4 at ON, 5 at OFF
2 - 10 V	3 at ON, 4 at OFF, 5 at ON

c. Closing direction setting (switch 6)

- When S6 is set to OFF, the closing direction of output drive is CW (clockwise).
- When S6 is set to ON, the closing direction of output drive is CCW (counter-clockwise).

⚠ The input signal type is set by switches 1 and 2. And switch 6 is used to set the corresponding relationship between value of input signal and operation direction of actuator as shown in the figure below, e.g., 4 - 20 mA input signal.

⚠ The operating direction of the actuator has been set and calibrated at the factory. Be sure to change the direction of the position indicator if different operating direction is required.

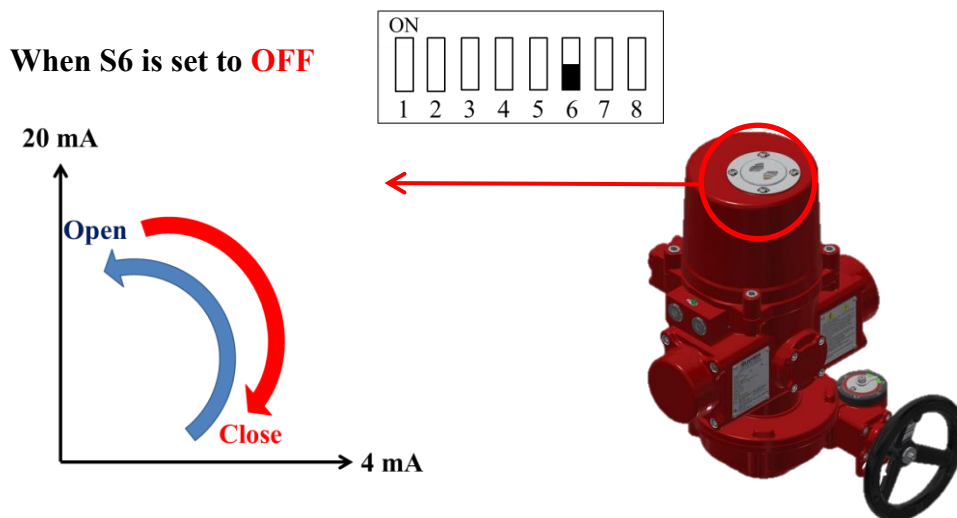

Position Indicator (Fully-Open→Fully-Closed)	Operating Position	Input Signal	LED	Output Signal
CW	Fully-Closed	1 V, 2 V, 4 mA	LD1 ON	2 V, 4 mA
	Fully-Open	5 V, 10 V, 20 mA	LD2 ON	10 V, 20 mA

【SE Series】 Explosion-proof Spring Return Fail-safe Electric Valve Actuator

When S6 is set to **ON**

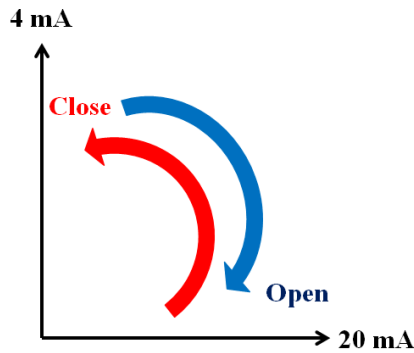
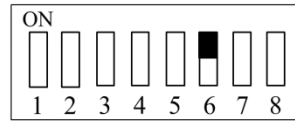

Position Indicator (Fully-Open→Fully-Closed)	Operating Position	Input Signal	LED	Output Signal
CCW	Fully-Closed	1 V, 2 V, 4 mA	LD1 ON	2 V, 4 mA
	Fully-Open	5 V, 10 V, 20 mA	LD2 ON	10 V, 20 mA

d. Failed position setting while the input signal failed. (switches 7 and 8)

- When a low signal value is received, the actuator operates toward fully-closed position and when a high signal value is received, the actuator operates toward fully-open position.

Input Signal	Fully-Closed	Fully-Open
4 - 20 mA	4 mA	20 mA
1 - 5 V	1 V	5 V
2 - 10 V	2 V	10 V

- The selection of the fail position while the input signal failed, please follow table below:

Signal Failed Position	State of Switch
Fully-Open	7 at ON, 8 at OFF
Fully-Closed	7 at OFF, 8 at ON
The Last Position	7 at ON, 8 at ON 7 at OFF, 8 at OFF

6.4 P4 Terminal

- When lights LD5 to LD8 turn on and the input signal fails, the microprocessor sets P4 as a conductive contact. P4 can be connected to an alarm or other similar devices for warning functions.

6.5 Sensitivity Switch Setting (SW2)

- When the value of sensitivity (%) is lower, the resolution of the input signal will be higher, and relatively the dead band will be smaller. Excessive high resolution may cause the actuator to keep hunting and could not run to the desired position. If this situation happens, it is suggested to adjust the sensitivity setting.
- Setting Range:

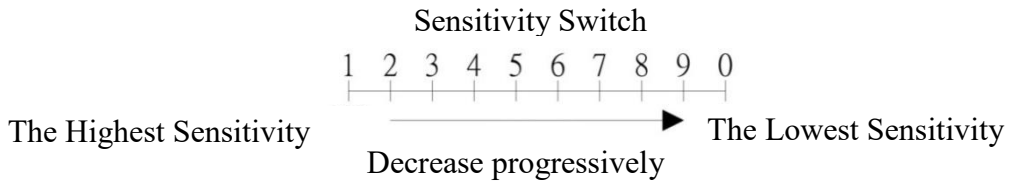

Setting Value	1	2	3	4	5	6	7	8	9	0
Sensitivity (%)	0.25	0.5	0.75	1	1.25	1.5	1.75	2	2.25	2.5

- When set to 1, it means that the allowable tolerance is $\pm 0.25\%$, which is the highest sensitivity.
- When set to 0, it means that the allowable tolerance is $\pm 2.5\%$, which is the lowest sensitivity.
- For example, if the sensitivity switch is set to 3 and the target position is 50%, the valid travel range will be from 49.25% to 50.75% as shown in the figure below.

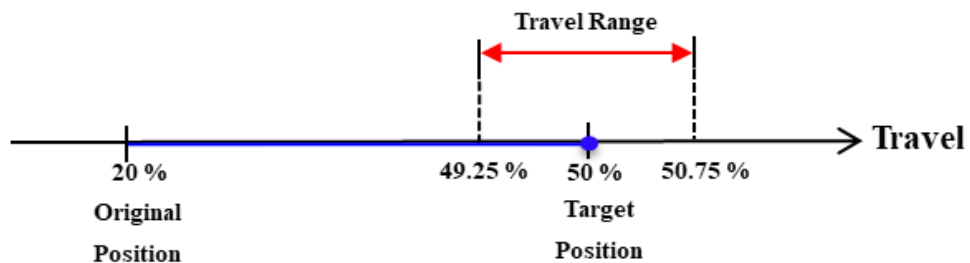

- Factory Default Setting:
 - SE-500 to SE-2600 : 3.

Model	Figure
SE-500 to SE-2600	

6.6 Signal Settings for OPEN and CLOSE Position

- ⚠ **These settings are set and calibrated at the factory. Mostly, they do not need to be recalibrated. Please follow steps below to set when required.**
- ⚠ **Use a multimeter to measure the output signal in accordance with the selected signal type.**

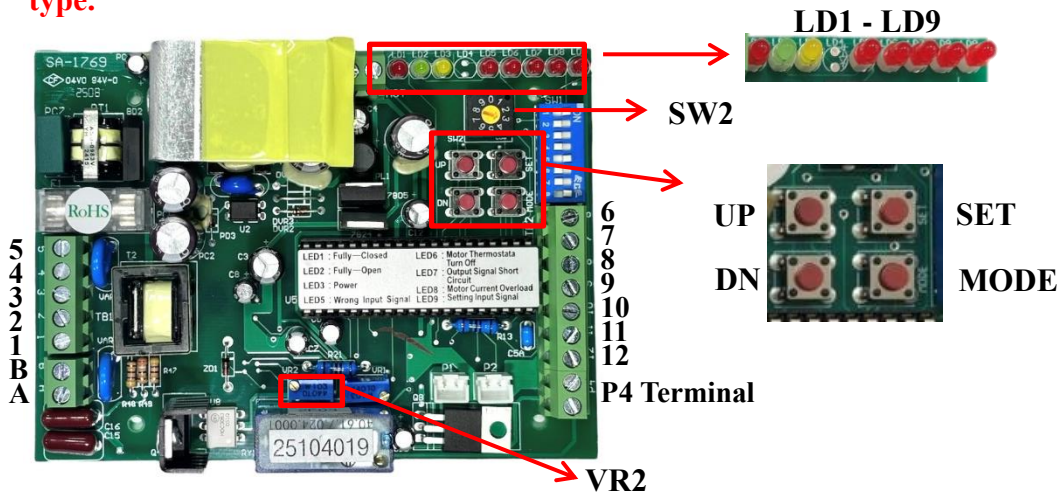

Lamp	Status	Lamp	Status
LD1	Fully-closed (Spring released)	LD6	Motor thermal protector activated
LD2	Fully-open (Spring compressed)	LD7	Output signal short circuit
LD3	Power	LD8	Overcurrent in motor
LD5	Wrong input signal	LD9	Local setting mode

Press and hold "SET" button for 2 seconds until LD 9 lights to enter local setting mode.

⚠ Please adjust the signal setting for fully-open position first, then adjust the signal setting for fully-closed position.

● **Signal setting for Fully-OPEN position (Spring compressed)**

- a. Press and hold "UP" button to operate the actuator to open until it has reached the fully-open position and LD2 lights. Input the signal according the setting value of dip switch and check if output signal is correct, if not, correct output signal, adjust VR2 until you achieve the correct output signal.

⚠ **VR2 can be used to adjust the output signal value.**

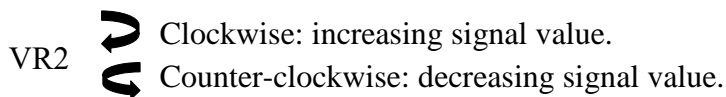

- b. Press "MODE" button for 2 seconds to complete the setting of fully-open position.

● **Signal setting for Fully-CLOSED position (Spring released)**

- a. Press and hold "DN" button to operate the actuator to close until it has reached fully-closed position and LD1 lights. Input the signal according the setting value of dip switch and check if output signal is correct, if not, correct output signal, adjust VR2 until you achieve the correct output signal.

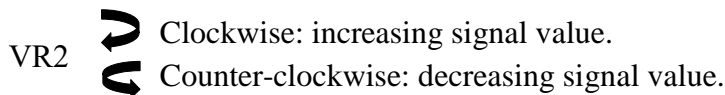

- b. Press "MODE" button for 2 seconds to complete the setting of fully-closed position.

After completing the above settings, press "SET" switch to quit local setting.

6.7 Troubleshooting of Modulating Control

- ⚠ In case LD3 does not light or any of LD5 to LD9 lights when the actuator is motorized, please refer to steps below for basic troubleshooting.**
- ⚠ Please do the troubleshooting when LD5 to LD9 lights, and then restart the power to turn the lights off.**

Status of LEDs	Possible problems	Solution
LD3 does not go on	a. No power supplied. b. Incorrect connection of the lines #8, #9 of the potentiometer c. Modulating control failed.	a. Check the power supply as well as wires connected to terminals #4 & #5, please refer to 6 (P.32). b. Verify the actuator is wired properly as per wiring diagram. c. Send back to the factory for inspection.
LD5 goes on	a. An incorrect signal type inputted. For example, preset with 2-10 V input but input 4 - 20 mA. b. Input a voltage exceeding the rated. For example, preset with 2-10 V input but input 13.5 V. c. An incorrect signal type inputted. For example, preset with 4 - 20 mA input but input 2 - 10V. In this case, the actuator still works in 2 - 7V. When the signal is over 7.2 V, the LD5 lights.	Verify if the switch 1 is set in accordance with the type of input signal. Please refer to 6.3 (P.33 to P.35).
LD 6 goes on	Motor thermal protector started.	a. The duty cycle exceeded the rated, please refer to 3.6 (P.11). b. The contact of motor thermal protector (MOT) disconnected.
LD7 goes on	a. Signal output short circuit. b. The input signal type 2 - 10 V with reversed polarity.	a. Verify if the signal output with reversed polarity. The negative pole should be connected to terminal #11 and the positive pole should be connected to terminal#12. b. Verify if the signal input with reversed polarity when applying 2 - 10 V, the negative pole should be connected to terminal #6 and the positive pole should be connected to terminal #7.
LD8 goes on	Motor over-current occurred, causing the motor to lock up.	a. Duty cycle exceeded the rated. Please refer to 3.6 (P.11) and reduce the duty rating. b. Check the load. c. Check if the motor rotor is locked (For example: Valve is stuck by foreign objects). Confirm and solve the above issues, press and hold “MODE” button for 2 seconds to unlock the motor.
LD9 goes on	Local setting mode - Setting position for open & close.	After completing setting, press “SET” button to quit.

7 Troubleshooting

⚠ If the actuator selected with handwheel , after doing handwheel operation, be sure to use the handwheel to turn back to fully-closed or fully-open (spring released) position before input the power, it can be operating normally.

Floating Control

Motor can not operate or overheats.

Possible problems	Solution
a. The seating torque of valve increased due to oxidized seals and has resulted in a torque overload on actuator.	a. Manual operate check if it can be operated, if not replace a new valve.
b. Jammed pipe or stuck valve seat.	b. Check if any blockage or obstacle in pipe and remove.
c. Motor shaft or bearing were stuck.	c. Replace a new motor.
d. The limit switch for fully-closed does not trip (with manual override).	d. Operate the actuator manually to fully-closed position and confirm if the limit switch trips.
e. The limit switch for fully-closed does not trip (without manual override).	e. Check if a torque overload caused by the valve.

The actuator functions normally but motor is hot.

Possible problems	Solution
a. Actuator operates too frequently and exceeded duty cycle rating.	a. Adjust the system bandwidth or reduce the frequency of operation.
b. A torque overload caused by the valve.	b. This situation occurs frequently after the valve has been operating for a period of time. It is suggested to replace with a new valve.
c. Wrong power supply.	c. Check the power supply.

To control two or more actuators, sometimes the actuator works abnormally and the motor is getting hot.

Possible problems	Solution
Parallel connection.	Check operating current values and install a relay respectively.

The valve cannot operate either electrical operation or manual operation.

Possible problems	Solution
<ul style="list-style-type: none"> a. The actuator was mounted to the valve improperly. b. The torque of valve is larger than the torque of actuator. c. The cap screw of the cam loosened and resulted in that the travel end positions misaligned. d. The OPEN and CLOSE end stop points of actuator are not aligned with valve. 	<ul style="list-style-type: none"> a. Please refer to 4.2 (P.16) installation steps. b. Replace a new valve or a larger size actuator. c. Readjust the mechanical stops and limit switches, please refer to 4.5 (P.19 to P.26). d. Separate the actuator from valve and reinstall to ensure the OPEN and CLOSE stop points are aligned properly.

The capacitor is faulty.

Possible problems	Solution
<p>Ambient temperature is excessively high or low.</p>	<p>The actuator should be installed within the rated ambient temperature range of -30 °C to +70 °C (-22 °F to + 158 °F).</p>

Modulating Control

The LED indicators (LD5 - LD9) flash.

Solution
Refer to 6.6 (P. 37).

The LED indicators on the modulating board are normal, but the actuator cannot operate or can only operate in either the fully-open or fully-closed position.

Possible problems	Solution
The signal input with a reversed polarity, it means a signal failure.	Verify if the negative pole of signal input connected to terminal #6 and the positive pole connected to terminal #7.

Modulating control is not functioning

Possible problems	Solution
<ul style="list-style-type: none"> a. The modulating board is faulty, and the actuator cannot operate or can only operate in one direction. b. Input wrong signal type. c. Modulating board failed and causes actuator can not operate or only operate in a single direction. 	<ul style="list-style-type: none"> a. Replace a new modulating board. b. Check if the input signal is correct, please refer to 6.3 (P.33 to P.35). c. Replace a new modulating board.

Spring cannot release to the right position in fully-open.

Possible problems	Solution
<ul style="list-style-type: none"> a. The spring could not release properly. 	<ul style="list-style-type: none"> a. Disassemble the actuator from the valve or damper and check if the spring can release successfully. <ul style="list-style-type: none"> - If yes, it might be caused by abnormal torque from the valve or damper. - If not, please contact your salesperson for further diagnostics.

8 Actuator Options







Fail clockwise (CW) rotation

When energized, the driven valve rotates CCW (viewed from the top of the actuator). Meanwhile, the springs are compressed. On loss of power, the spring returns (unloaded) and the driven valve rotates CW.

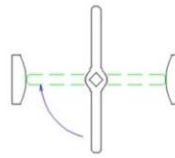

Fail counter-clockwise (CCW) rotation

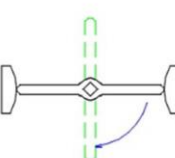
When energized, the driven valve rotates CW (viewed from the top of the actuator). Meanwhile, the springs are compressed. On loss of power, the spring returns (unloaded) and the driven valve rotates CCW.

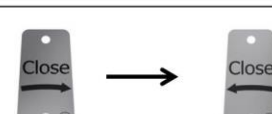
Valve operating direction	Desired fail position upon loss of supply voltage	Actuator Type	Handwheel direction
CW rotation for CLOSE 	Valve at fully-closed	CW	Direct mount per original factory setting. 
	Valve at fully-open	CCW	Adjust the tag and position indicator. 
CW rotation for OPEN 	Valve at fully-closed	CCW	Direct mount per original factory setting. 
	Valve at fully-open	CW	Adjust the tag and position indicator. 

⚠ If the manual override is optioned, be sure to rotate the handwheel to run the actuator to fully-closed or fully-open position (spring released) after completing the handwheel operation, and ensure that the manual device indication is within the green zone for normal electrical operation.

Instructions for adjusting the open/close indicator beacon:

1. Loosen the screws of position indicator window (Figure 1).
2. Rotate the position indicator window by 90 degrees and tighten the screws (Figure 2).

The tag of CLOSE direction with an arrow pointing on the handwheel is printed on both of the sides A and B as Figure 4. Please adjust its direction in accordance with the configuration.

1. Loosen the screws of tag and adjust the tag to reflect the correct CLOSE direction (Figure 3).
2. Adjust the tag to side B (counter-clockwise in the closing direction) and tighten the screws (Figure 4).

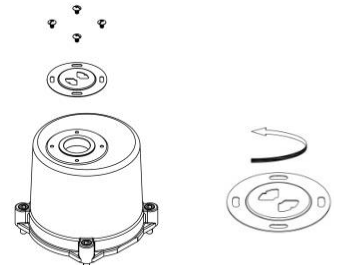

(Figure 1)



(Figure 2)



(Figure 3)



A

B

(Figure 4)

9 Warranty

Sun Yeh Ele. Co. Ltd. warrants that for a period of twelve months from the date of manufacture it will either repair or replace, at its option, any of its products which prove to be defective in material or workmanship. This warranty does not cover damage resulting from causes such as abuse, misuse, modification or tampering by users. This warranty is extended only to the immediate purchaser of Sun Yeh product and is not transferable. To obtain service under this warranty, the purchaser must first acquire a return authorization from Sun Yeh. Products must be returned to Sun Yeh under freight prepaid.

This warranty is in lieu of all other obligations, liabilities or expressed warranties. Any implied warranties, including any implied warranty of merchantability are hereby expressly excluded. In no event shall Sun Yeh be liable for special, incidental or consequential damages arising in connection with the use of its products, or for any delay in the performance of this warranty due to cause beyond its control.

10 Disposal

Please obey the local environment regulation for equipment scrapping.



SUNYEH ELECTRICAL IND. CO., LTD.

No.68, Ln. 854, Sec. 1, Shatian Rd., Dadu Dist.,
Taichung City 432, Taiwan
Tel: +886-4-26985666 Fax: +886-4-26983668
E-mail: service@sunyeh.com



www.sunyeh.com