

# DM-20

---

SuperCap Fail-safe  
Electric Valve Actuators



## OPERATION MANUAL



**SUN YEH ELECTRICAL IND. CO., LTD.**

SY11-C001A-EN

## Contents

1	General Information .....	1
1.1	Safety Instructions .....	1
1.2	Installation Notices .....	1
1.3	Inspection, Storage, Transport .....	2
2	Product Overview .....	3
2.1	Product Features .....	3
3	Product Mechanical Data.....	4
3.1	Parts Identification.....	4
3.2	Technical Information.....	5
3.3	Mounting Base Details .....	5
3.4	Sizing .....	5
3.5	Duty Cycle .....	6
3.6	Valve Mounting Instructions.....	7
3.7	Wiring Instructions .....	8
4	Manual Operation & LED Status / Alarm Indication Instructions .....	9
4.1	Manual Device Installation.....	9
4.2	LED Status / Alarm Indication .....	10
5	PCB Setting .....	11
5.1	Master Control Board .....	11
5.2	Modulating Board.....	14
5.3	Capacitor Board .....	14
6	Troubleshooting.....	32
7	Warranty .....	35
8	Disposal .....	35

## 1 General Information

**⚠ Failure to follow safety instructions may cause serious injury, equipment damage, or voided warranty.**

### 1.1 Safety Instructions

- Installation, maintenance and repair works must be performed by trained personnel.
- The handling shall follow the safety and warning instruction contained in this manual.
- Before operation, the user should read and follow instructions contained in this operation manual. Failure to do this may result in damages and void warranty. Sun Yeh will not be liable for damages due to operator negligence or misuse.
- Local health and safety legislation shall be complied with.
- In a few cases, the surface temperature may exceed 60 °C (140 °F). Please check the surface temperature before operation, using an appropriate thermometer and wearing protective gloves before operation.

### 1.2 Installation Notices

**⚠ Operating by manual device :**  
**Actuators equipped with manual device, please refer to 4.1 Valve Mounting Instructions. Do not use any tools other than wrench to increase opening / closing torque (Max. torque: 1.9 Nm) as this can damage the actuator or valve.**

- Please read operation manual and wiring diagram carefully before installation.
- Verify that supply voltage is in accordance with the data on nameplate to prevent short circuit or electrical / electronic parts damage caused by incorrect power input.
- Turn power off before wiring or maintenance.
- Connect the ground wire to PE point on power board inside the electric actuator.
- To avoid functional failure caused by static, do not touch any components on the PCBA with metal tools or bare hands.
- Use suitable water-proof cable gland to ensure it fits the conduit entry size, diameter of the cable and the enclosure protection of the actuator when wiring. The water-proof cable gland must be tightened and flattened to the cable after wiring procedure and use original black water-proof plug to seal unused conduit entry and fasten the top cover of the actuator to prevent dust or water from entering the actuator. The red plastic dust-proof plug is not meant for long-term use. Replace it with suitable water-proof connector to ensure the enclosure protection rating.
- Actuator should be installed in an upright or horizontal position. Do not mount upside down or below a horizontal position.
- These units are not designed to operate in vacuum spaces or where an explosive atmosphere exists.
- Periodically inspect actuator enclosure to prevent dust from accumulating.

## 1.3 Inspection, Storage, Transport

### 1.3.1 Receiving / Inspection

- Carefully inspect the package for any damages resulting from shipping and report all damages to the freight carrier and seller.
- After unpacking the product and information packet, please keep the cartons and any packing materials in case of product return or replacement. Verify that the items on the packing slip or on the bill of lading are the same as what were ordered. If there is any discrepancy, please contact the seller.
- Verify if the technical data on nameplate is accordance with what was ordered.

### 1.3.2 Storage

- The actuator should be stored in a dry area with relative humidity of less than 90 % and at temperatures between -20 °C to +40 °C (-4 °F to +104 °F).
- The product shall be stored with suitable protection from corrosive substance that can damage the metal and insulating parts.
- The red dustproof plug and black waterproof plug should not be removed until the actuator is ready to be cabled. Use suitable cable glands with IP 66 protection when wiring and seal the unused cable entry with original black waterproof plug.

### 1.3.3 Transport

- Actuators packaged in cartons can stand up to land, sea, or air transportation.
- Packaged actuators shall avoid of violent impact and strong vibrations and be protected from rain or snow.

### 1.3.4 Lubrication

- The gear train has been sufficiently lubricated at the factory. No additional lubrication is required.

## 2 Product Overview

SuperCap fail-safe actuator offers a torque output of 20 Nm (177 in-lb), which uses supercapacitors to operate dampers or valves to safe position (fully OPEN or CLOSED) when the power supply is lost, to achieve electronic fail-safe positioning function. It also has many other features, such as multi-voltage design, plug-and-play modular design, electronic torque limiting device, LED status / alarm indication, adjustable travel, and floating or modulating control.

### 2.1 Product Features

- SuperCap fail-safe positioning.
- Multi-voltage design (optional).
- Modular plug and play design.
- Electronic limit position.
- Electronic torque limiting device.
- LED status / alarm indication.
- ISO 5211 flange types F03 / F04 / F05.
- ISO 22153 duty classes A, B, and C.
- Manual operation permitted if power is lost.
- Enabling parallel operation of multiple actuators.



### 3 Product Mechanical Data

#### 3.1 Parts Identification

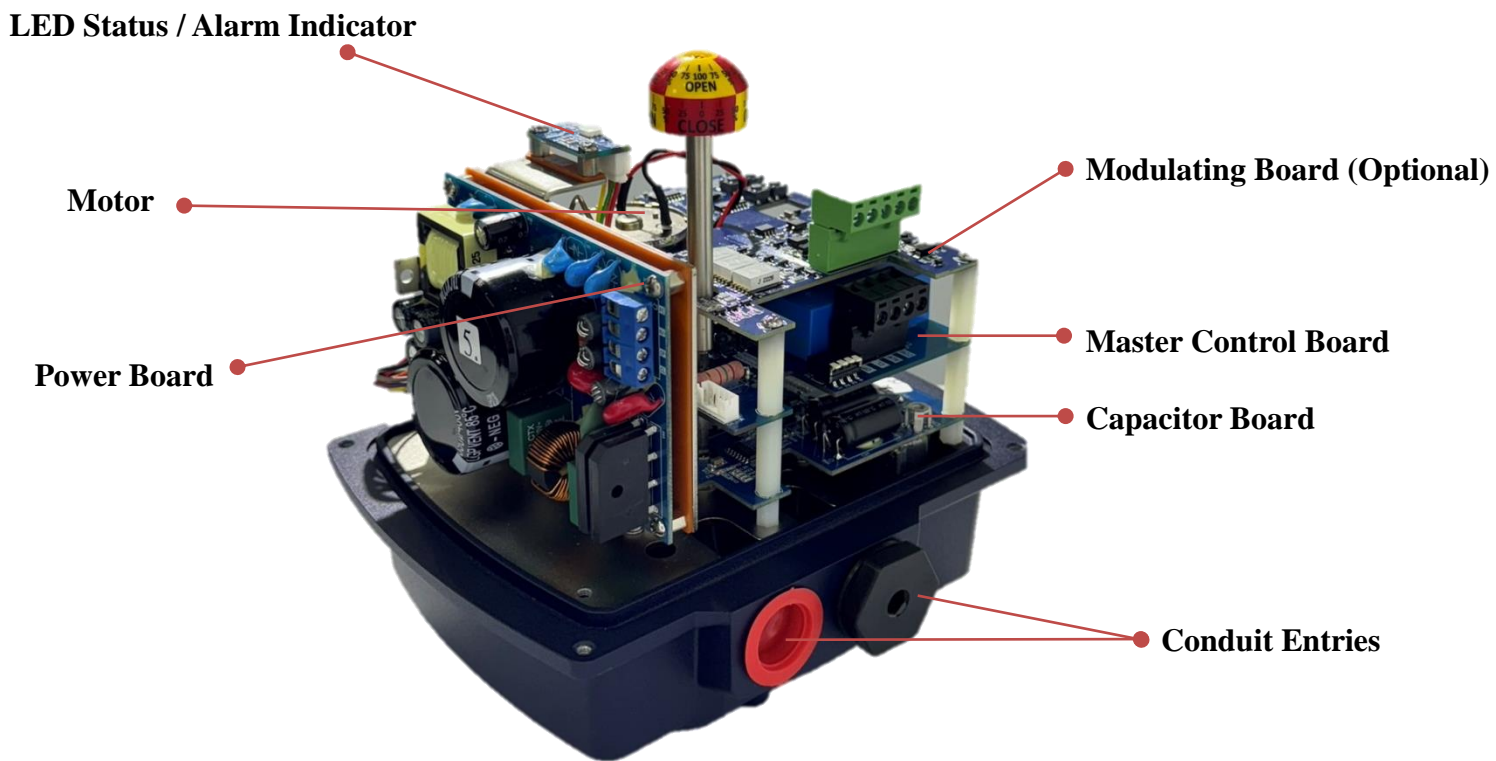
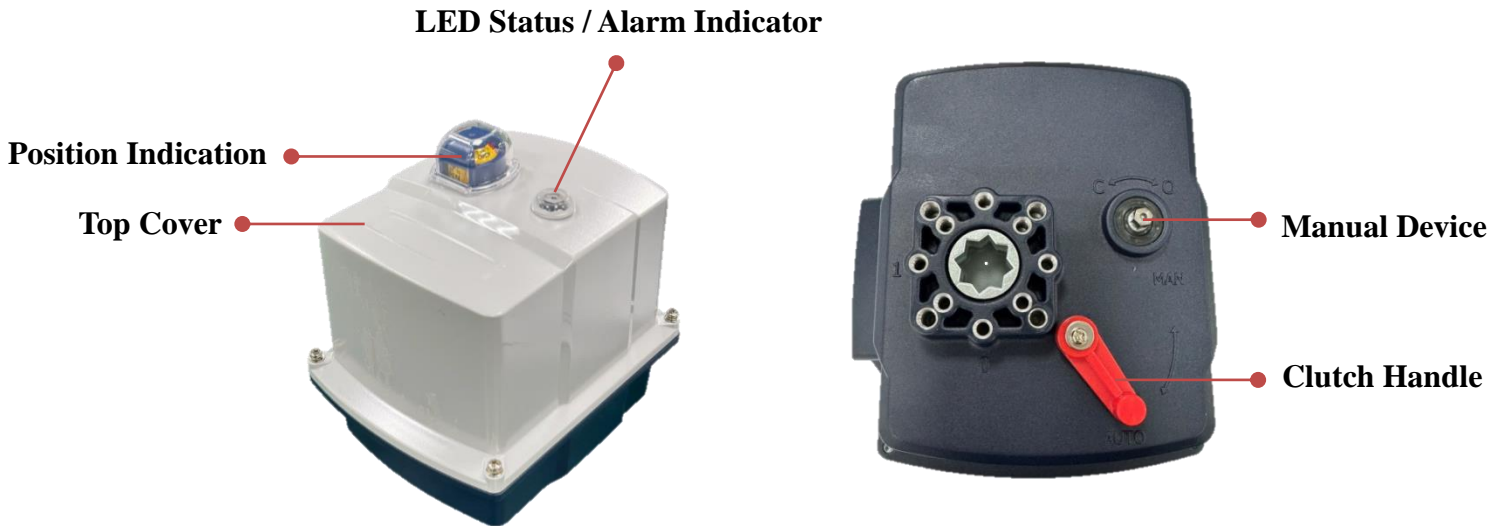

# 【DM-20】 SuperCap Fail-safe Electric Valve Actuator

## 3.2 Technical Information

Model	Torque		Weight		Nominal Motor Power	Manual Override	Flange Type
	Nm	in-lb	kg	lb	W		ISO 5211
DM-20	20	177	2.2	4.85	17	Lever	F03 / F04 / F05

## 3.3 Mounting Base Details

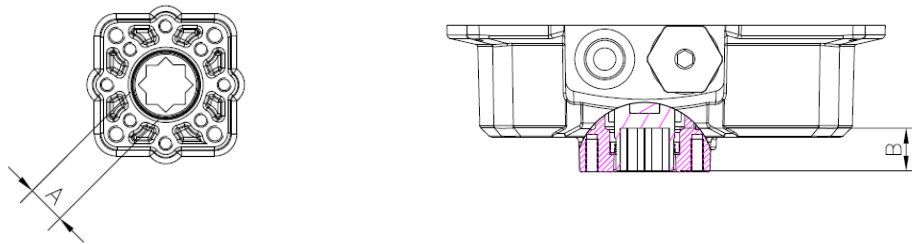

Model	Flange Type	Output Drive (A)		Depth of Output Drive (B)	
	ISO 5211	mm	inch	mm	inch
DM-20	F03 / F04 / F05	14	0.551	17	0.669

## 3.4 Sizing

- a. The actuator shall be sized to ensure that its torque output meets the load requirements of valve and its ability to overcome the required duty cycle of application.

- If the maximum torque of 1" valve is 10 Nm →  $10 \times 1.3$  (safety factor) = 13 Nm  
 $13 \text{ Nm} < 20 \text{ Nm (DM-20)} \rightarrow \text{OK!}$   
**⚠ As a MINIMUM, a 30% safety factor is suggested for the calculation of torque requirement.**

- b. In cases where the actuator does not directly fit onto the valve, a mounting kit is required. Please ensure the bracket and coupling are properly designed and manufactured to withstand the torque output of the actuator.

# 【DM-20】 SuperCap Fail-safe Electric Valve Actuator

## 3.5 Duty Cycle

- DM-20 can be classified into Class A (On-off), B (Floating), and C (Modulating) according to ISO 22153 as follows:

Type \ Model	Class A	Class B	Class C (Optional)
	cycles / hour	starts / hour	starts / hour
DM-20	15	120	1200

### ➤ Class A

**One Cycle = 90° Open + rest time + 90° Close + rest time.**

- If the running time for DM-20 is 9 sec, 15 cycles / hour,  
One cycle =  $3,600 \text{ sec} \div 15 = 240 \text{ sec}$   
→  $[240 - (9 \times 2)] / 2 = 111$ , the rest time will be 111 sec.

### ➤ Class B

**One Cycle = run time + rest time.**

**⚠ The cycle duration factor should be not less than 25%.**

- If the duty performance for DM-20 is 120 starts / hour, 25% duty cycle, the rest (off) time shall be calculated as below:  
One start =  $3,600 \text{ sec} \div 120 \text{ starts} = 30 \text{ sec}$ .  
Running time =  $30 \text{ sec} \times 25 \% = 7.5 \text{ sec}$ .  
→  $30 - 7.5 = 22.5$ , the rest time will be 22.5 sec.

### ➤ Class C

**One Cycle = run time + rest time.**

**⚠ The cycle duration factor should be not less than 25%.**

- If the duty performance for DM-20 is 1200 starts / hour, 25% duty cycle, the rest (off) time shall be calculated as below:  
One start =  $3,600 \text{ sec} \div 1200 \text{ starts} = 3 \text{ sec}$ .  
Running time =  $3 \text{ sec} \times 25 \% = 0.75 \text{ sec}$ .  
→  $3 - 0.75 = 2.25$ , the rest time will be 2.25 sec.



## 3.6 Valve Mounting Instructions

Make sure both the valve and actuator are in the same position before mounting, either fully-open or fully-closed. If not, switch the clutch handle from electrical operation (AUTO) to manual operation (MAN). Use a 6 mm open-end wrench to rotate the manual device (Max. torque: 1.9 Nm) to align the output drive marking with either 0 (fully-closed) or 1 (fully-open) mark on the base. Then, mount the actuator with the valve. Switch the clutch handle back to electrical operation (AUTO). For example: The actuator is in fully-open position and the valve is in fully-open position as well.

**⚠ If mounted with damper, mount the damper with actuator in closed position first, then readjust the angle of open position.**

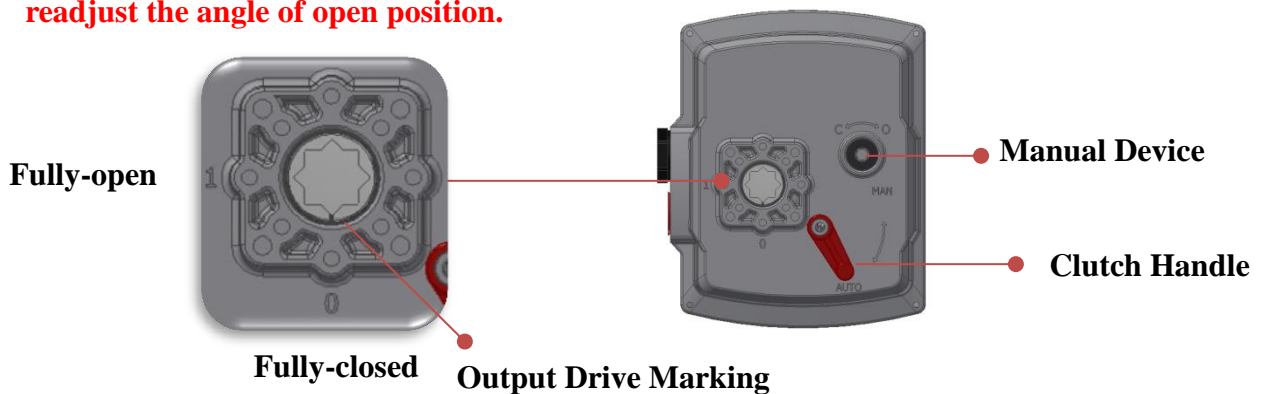

- Once mounted together, either directly or with a mounting kit, ensure that they are properly secured together and all fasteners are tightened.
- Check again that the valve and actuator are in the same position.
- Remove the conduit entry plug to relieve the pressure inside the actuator for the ease of the top cover removal and gently remove the cover.

**⚠ The power must be off before removing the cover.**



- Refer to section 3.7 (P.8) for wiring instructions and connect the wires according to the wiring diagram labeled inside the cover of actuator.
- Supply power to actuator.  
**⚠ Care must be taken at all times as there are live circuits present that may cause electrical shock.**
- Assemble the cover and secure cover screws firmly after setting.  
**⚠ Please ensure that the O-ring seal is in good condition prior to cover installation.**

## 3.7 Wiring Instructions

- ⚠ Turn power off before making the electrical connection!**
- ⚠ Supply power for at least 5 minutes before first operation to ensure the actuator has sufficient power to do the fail-safe return.**

- Connecting the ground wire to PE point on power board and wiring according to the wiring diagram inside the top cover.

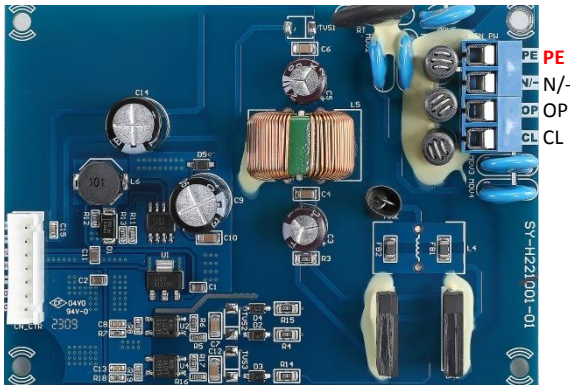

- Each actuator is attached with a black water-proof plug and a temporary red dust-proof plug to conduit entries.
  - ⚠ Use correct size of fittings so as to not damage the threads.**
- Verify the supply power is in accordance with the data on the nameplate to prevent a short circuit and an electrical shock.
  - ⚠ Do not apply power to actuator before wiring, otherwise it can cause an electrical shock or damage components of the actuator.**
- The red plastic dustproof plug is not meant for long-term use. Use suitable cable glands with IP 66 protection when wiring and seal the unused cable entry with original black waterproof plug.

## 4 Manual Operation & LED Status / Alarm Indication Instructions

### 4.1 Manual Operation

- Switch the clutch handle from electrical operation (AUTO) to manual operation (MAN).
- Use a 6 mm open-end wrench (max. torque: 1.9 Nm) to rotate the manual device either clockwise to open (O) or counter-clockwise to close (C).  
**⚠ This is demonstrated by viewing from the bottom of the output drive.**
- After manual operation, switch the clutch handle from manual operation (MAN) to electrical operation (AUTO).  
**⚠ After manual operation, switch to electrical operation (AUTO) to enable motorized actuator, otherwise the actuator will not operate properly.**

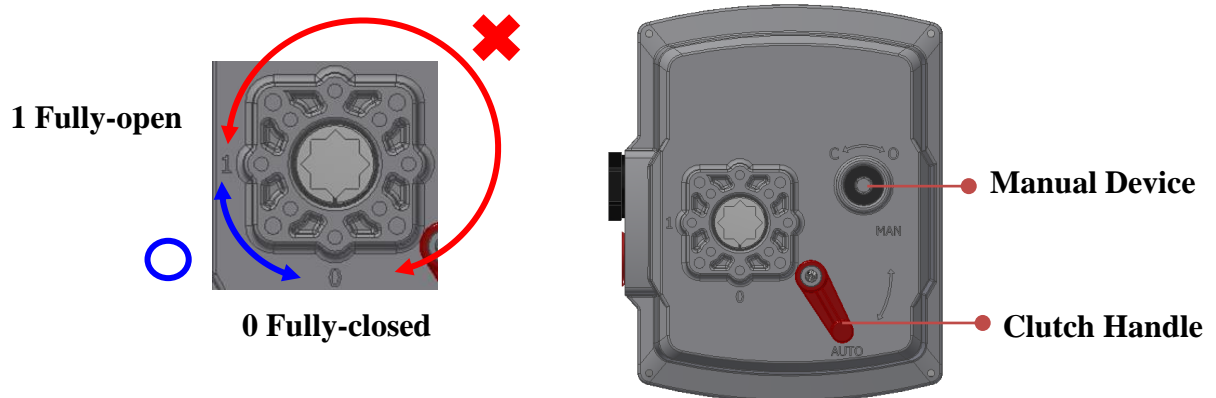

- During manual operation, the blue arrow indicates the normal range of output drive rotation. If the output drive rotation falls within the range marked by the red arrow, it indicates exceeding the fully-open or fully-closed limit positions, and the LED indicator will display E45 (4 long flashes and 5 short flashes) or E46 (4 long flashes and 6 short flashes) in yellow. Refer to 4.2 LED Status / Alarm Indication (P.10) and 6 Troubleshooting (P.32 to 34) for more information.

## 4.2 LED Status / Alarm Indication

- In addition to providing the current operating status as shown in the table below, when the LED status / alarm indicator flashes in yellow, the length and frequency of the flashes represent different warning messages. Refer to 5.3.6 Troubleshooting Error Code (P.30 to P.301) for more information.  
For example, when the LED indicator displays 2 long flashes and 1 short flash in yellow, the error code is 21.
- The following table shows actuator status when the dip switch S1 to S4 is set at OFF.



**LED Status / Alarm Indicator**

Lamp Status	Actuator Status
Red On	Fully-open
Red Light Flashing	Opening Direction
Green On	Fully-closed
Green Light Flashing	Closing Direction
Yellow On	Stop at Intermediate Position
Yellow Light Flashing	Fault

## 5 PCBA Setting

**⚠ Power must be off before installing or removing the module to avoid danger.**

### 5.1 Master Control Board

#### 5.1.1 Surface

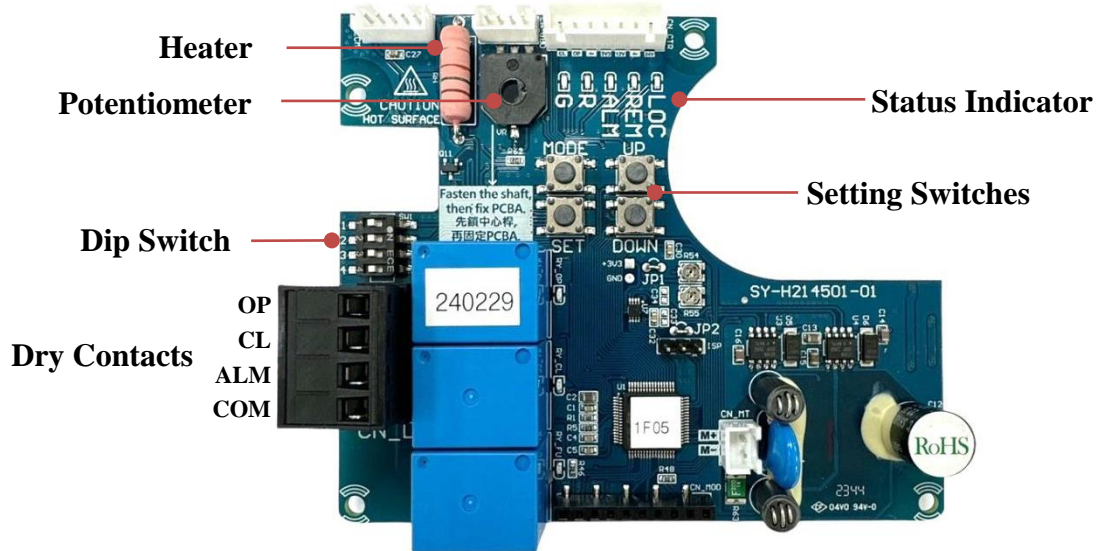

- Lamp Status

Lamp Code	Lamp Color	Actuator Status	
		S2 OFF	S2 ON
G		Light on: Fully-closed Flashing: Closing Direction	Light on: Fully-open Flashing: Opening Direction
R		Light on: Fully-open Flashing: Opening Direction	Light on: Fully-closed Flashing: Closing Direction
ALM		Alerting Signal	
REM		Remote Control Mode	
LOC		Local Control Mode	

## 5.1.2 Dip Switch Setting (SW1)



The Dip Switch SW1 is a combination of 4 switches S1 to S4, which are used for fail-safe direction, indicator color of open /closed direction and the setting of close direction definition. The sliders can be placed at either ON (lower) or OFF (upper) state position. Factory settings are switches 1, 2, 3, 4 at OFF state (S4 is no function).

a. Supercapacitors Fail-safe Direction (S1)

Setting	Output drive operating direction when power is lost
OFF	CW
ON	CCW

b. Indicator Color of Open / Closed Direction (S2)

Setting	Opening direction	Closing direction
OFF	Red	Green
ON	Green	Red

**⚠ The adjustment of S2 only affects the color of LED status / alarm indicator.**

c. Closing Direction Definition (S3)

Setting	Output drive operating direction during closing direction
OFF	CW
ON	CCW

**⚠ The position indicator is set per S3 setting at factory. Please readjust the position indicator accordingly if the setting of S3 has been changed.**



### 5.1.3 Fully-open and Fully-closed Limit Position Setting

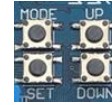

**⚠ Use setting switches to readjust the fully-open and fully-closed limit position if needed.**

- a. Press and hold “SET” for 3 seconds until “LOC” lamp comes on and “REM” lamp comes off to enter setting mode. Press the “UP” and “DOWN” buttons to perform open and close settings. Press “UP” to run the actuator toward opening direction and press “DOWN” to run the actuator toward closing direction.
- b. Fully-CLOSED Limit Position Setting
  - Press and hold “DOWN” to operate the actuator to desired fully-closed position and press “MODE” for 3 seconds until fully-closed indicator lights on to complete the setting of fully-closed limit position.
    - ※ The indicator color is set according to the dip switch S2, and the factory default setting for the closed direction is **green**.
- c. Fully-OPEN Limit Position Setting
  - Press and hold “UP” to operate the actuator to desired fully-open position and press “MODE” for 3 seconds until the fully-open indicator lights on to complete the fully-open limit position setting.
    - ※ The indicator color is set according to the dip switch S2, and the factory default setting for the open direction is **red**.
- d. Press ”SET” once until “REM” lamp comes on and “LOC” lamp comes off to quit local control setting.

# 【DM-20】 SuperCap Fail-safe Electric Valve Actuator

## 5.2 Capacitor Board

**⚠ Power must be off before installing or removing the module to avoid danger.**

- Function: Supercapacitors are used to supply power to operate the dampers or valves to safe position (fully OPEN or CLOSED) when power is lost.
  - Pre-charging time: 5 minutes (24 V DC power at 25 °C).
  - Supercapacitors are charged in line power, and are used to operate the actuators to the fail-safe position when power is lost.
  - The charging indicator remains on when a capacitor board is charging and turns off when the charging is completed.
- Capacitor lifespan:
  - The lifespan is 160,000 hours at ambient temperature 25 °C.
  - The lifespan is 14,000 hours at ambient temperature 60 °C.

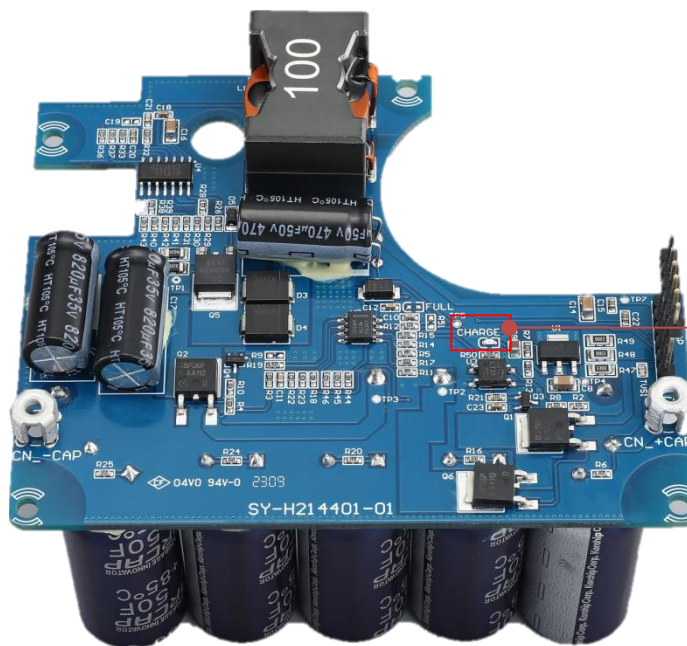

Charging Indicator

# 【DM-20】 SuperCap Fail-safe Electric Valve Actuator

## 5.3 Modulating Board

- ⚠ **Power must be off before installing or removing the module to avoid danger.**
- ⚠ **If the LED display is not operated for ten minutes, it will go out and return to the first level. Please press any button to display it again. In local control mode, the LED display will return to remote control mode after it goes out.**
- ⚠ **Please refer to 5.3.5 (P.18) for parameter setting when installing the modulating board.**



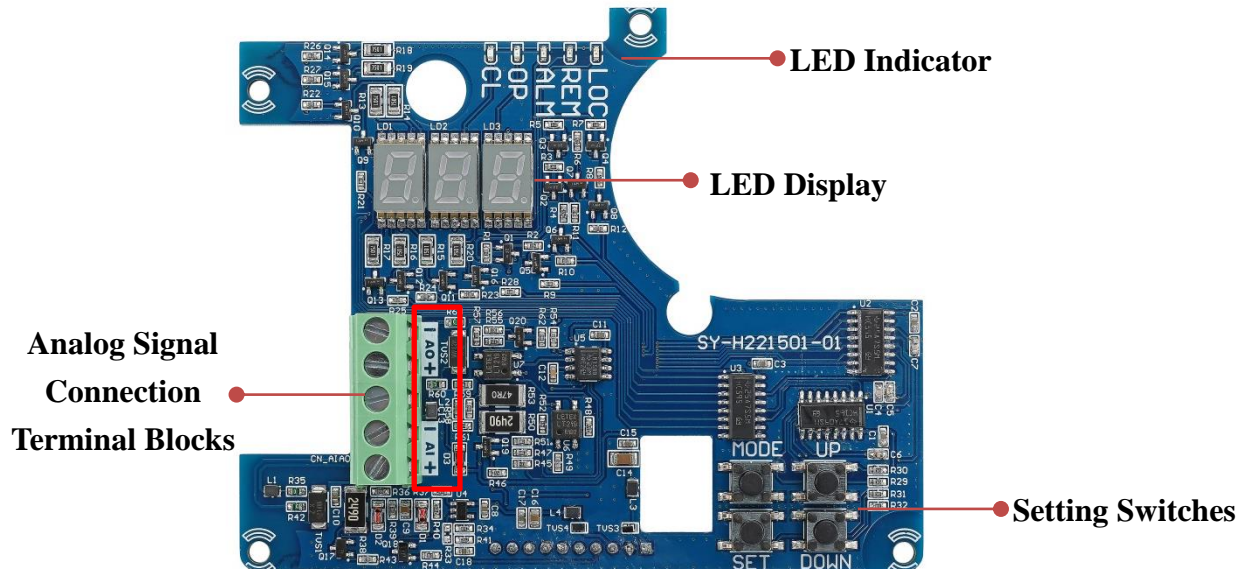

### 5.3.1 Surface



- Analog Signal Connection Terminal Blocks

Terminal	Status
AO -	Analog Signal Output (-)
AO +	Analog Signal Output (+)
	N/A
AI -	Analog Signal Input (-)
AI +	Analog Signal Input (+)

- Lamp Status

Lamp Code		Actuator Status
CL		Light on: Fully-closed Flashing: Closing Direction
OP		Light on: Fully-open Flashing: Opening Direction
ALM		Alerting Signal
REM		Remote Control Mode
LOC		Local Control Mode

# 【DM-20】 SuperCap Fail-safe Electric Valve Actuator

## 5.3.2 Startup Screen

- After supplying power, the LED display in sequence as follows: all lit, firmware version, input signal type, output signal type.
- Code Instruction:

142



- First digit: “i” stands for input signal
- Second and third digits:
  - 42 stands for 4 - 20 mA.
  - 02 stands for 0 - 20 mA.
  - 15 stands for 1 - 5 V.
  - 05 stands for 0 - 5 V.
  - 21 stands for 2 - 10 V.
  - 01 stands for 0 - 10 V.

021



- First digit: “o” stands for output signal
- Second and third digits:
  - 42 stands for 4 - 20 mA.
  - 02 stands for 0 - 20 mA.
  - 15 stands for 1 - 5 V.
  - 05 stands for 0 - 5 V.
  - 21 stands for 2 - 10 V.
  - 01 stands for 0 - 10 V.

Signal Type	4 - 20 mA	0 - 20 mA	1 - 5 V	0 - 5 V	2 - 10 V	0 - 10 V
LED Display	42	02	15	05	21	01

- Below example is for input signal 4 - 20 mA and output signal 2 - 10 V.

Instruction	All Lit	Firmware Version	Input Signal Type	Output Signal Type
LED Display	8.8.8.	F01	142	021

# 【DM-20】 SuperCap Fail-safe Electric Valve Actuator

## 5.3.3 Settings Menu

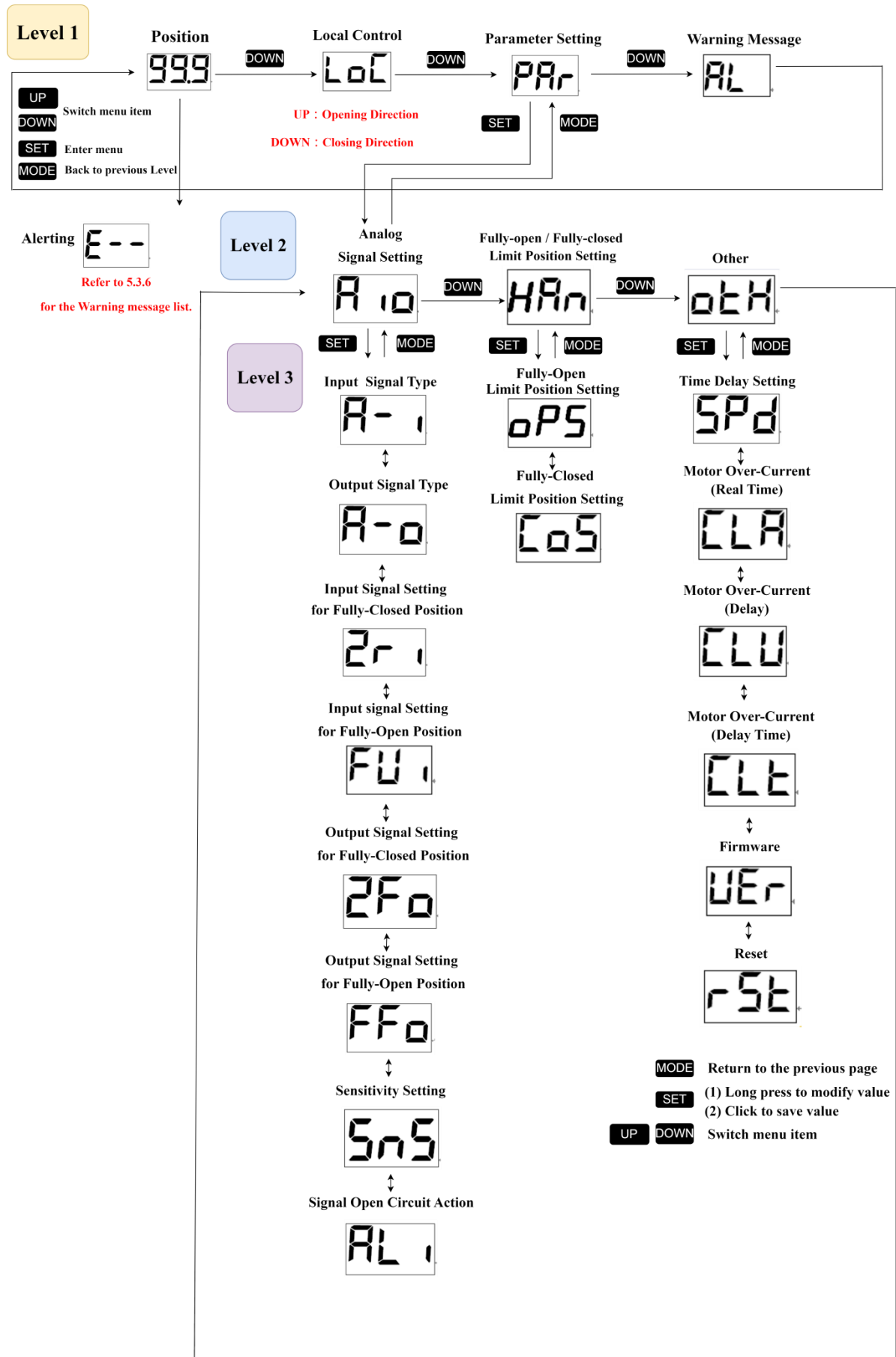



## 5.3.4 Local Control LoC

- The actuator could be directly controlled in the field.
- Setting Range: 0% to 100%.
- Setting Steps:
  - a. Press “DOWN” several times to get into LoC.
  - b. Press “SET” until LoC displays to enter local control mode. The display will show the current position and the LoC lamp will light on.
  - c. Press “UP” to run the actuator toward opening direction and press “DOWN” to run the actuator toward closing direction.
  - d. Press “MODE” to return remote control mode after the opening direction (CW) or closing direction (CCW) operation are completed.

## 5.3.5 Parameter Setting PAR

- Signal and other parameters setting.

**[Analog Signal Setting]** A 10

-  **Use a multimeter to measure the output signal in accordance with the selected signal type.**
-  **Be sure to complete the input / output signal type setting before setting the fully-closed / fully-open input / output signal.**

- a. Input signal type A- 1
  - Input signal type setting.
  - Factory default setting: 000
  - Setting Steps:
    1. Press “DOWN” several times until PAR displays, then press “SET” once to enter parameter setting.
    2. Press “UP” or “DOWN” until A 10 displays, then press “SET” once to enter analog signal setting.
    3. Press “UP” or “DOWN” until A- 1 displays, then press “SET” once to enter input signal type setting.
    4. Press and hold “SET” around 3 sec until the indicator shows the parameter code and flashes.



## 【DM-20】 SuperCap Fail-safe Electric Valve Actuator

5. Press “UP” or “DOWN” to select desired parameter code according to the following table.

Parameter Code	Input Signal Type
000	4 - 20 mA
001	0 - 20 mA
002	1 - 5 V
003	0 - 5 V
004	2 - 10 V
005	0 - 10 V

6. Press “SET” once to complete input signal type setting.

b. Output Signal Type **A-o**





- Output signal type setting.
- Default Setting: **000**
- Setting Steps:
  1. Press “DOWN” several times until **PAR** displays, then press “SET” once to enter parameter setting.
  2. Press “UP” or “DOWN” until **A io** displays, then press ”SET” once to enter analog signal setting.
  3. Press “UP” or “DOWN” until **A-o** displays, then press “SET” once to enter output signal type setting.
  4. Press and hold “SET” around 3 sec until the display shows the parameter code and flashes.
  5. Press “UP” or “DOWN” to select desired parameter code according to the following table.

Parameter Code	Output Signal Type
000	4 - 20 mA
001	0 - 20 mA
002	1 - 5 V
003	0 - 5 V
004	2 - 10 V
005	0 - 10 V

6. Press “SET” once to complete output signal type setting.

## 【DM-20】 SuperCap Fail-safe Electric Valve Actuator

### c. Input Signal Setting for Fully-closed Position

- Set the input signal value for fully-closed position.
- Setting Range: 000 to 4095.
  - The LED display is designed with hexadecimal format, so the value of 4095 is displayed as FFF.
- Setting Steps:
  1. Press “DOWN” several times until  displays, then press “SET” once to enter parameter setting.
  2. Press “UP” or “DOWN” until  displays, then press “SET” once to enter analog signal setting.
  3. Press “UP” or “DOWN” until  displays, then press “SET” once to enter input signal setting for fully-closed mode.
  4. Press and hold “SET” around 3 sec until the display shows the value and flashes.
  5. Use a signal generator to output 4 mA, 1 V, or 2 V based on the setting of , then press "SET" once to complete the input signal setting of fully-closed position.

 **When the signal type of 0 - 20 mA, 0 - 5 V, or 0 - 10 V is selected, input the calibration signal value of 4 mA, 1 V or 2 V to perform the setup.**

Signal Type	Calibration Signal Value
4 - 20 mA	4 mA
0 - 20 mA	
1 - 5 V	1 V
0 - 5 V	
2 - 10 V	2 V
0 - 10 V	

## 【DM-20】 SuperCap Fail-safe Electric Valve Actuator

### d. Input Signal Setting for Fully-open Position FU

- Set the input signal value for fully-open position.
- Setting Range:000 to 4095 ◦
  - The LED display is designed with hexadecimal format, so the value of 4095 is displayed as FFF.
- Setting Steps:
  1. Press “DOWN” several times until PAR displays, then press “SET” once to enter parameter setting.
  2. Press “UP” or “DOWN” until A 10 displays, then press “SET” once to enter analog signal setting.
  3. Press “UP” or “DOWN” until FU displays, then press “SET” to enter input signal setting for fully-open mode.
  4. Press and hold “SET” around 3 sec until the indicator shows the value and flashes.
  5. Use a signal generator to output 20 mA, 5 V, or 10 V based on the setting of A-, then press "SET" once to complete the input signal setting of fully-open position.

**⚠ When the signal type of 0 - 20 mA, 0 - 5 V, or 0 - 10 V is selected, input the calibration signal value of 20 mA, 5 V or 10 V to perform the setup.**

Signal Type	Calibration Signal Value
4 - 20 mA	20 mA
0 - 20 mA	
1 - 5 V	5 V
0 - 5 V	
2 - 10 V	10 V
0 - 10 V	

## 【DM-20】 SuperCap Fail-safe Electric Valve Actuator

- e. Output Signal Setting for Fully-closed Position **2F0**
- Set the output signal value for fully-closed position.
  - Setting Range: 000 to 4095.
    - The LED display is designed with hexadecimal format, so the value of 4095 is displayed as FFF.
  - Setting Steps:
    1. Press “DOWN” several times until **PAR** displays, press “SET” once to enter parameter setting.
    2. Press “UP” or “DOWN” until **A 10** displays, then press “SET” once to enter analog signal setting.
    3. Press “UP” or “DOWN” until **2F0** displays, then press “SET” once to enter output signal setting for fully-closed mode.
    4. Press and hold “SET” around 3 sec until the display shows the value and flashes.
    5. Press “UP” or “DOWN” to adjust the value until the signal meter receives the value of 4 mA, 1 V or 2 V according to the output signal type of **A-0** setting. Then press “SET” once to complete the output signal setting for fully-closed position.
- ⚠ When the signal type of 0 - 20 mA, 0 - 5 V, or 0 - 10 V is selected, input the calibration signal value of 4 mA, 1 V or 2 V to perform the setup.**

Signal Type	Calibration Signal Value
4 - 20 mA	4 mA
0 - 20 mA	
1 - 5 V	1 V
0 - 5 V	
2 - 10 V	2 V
0 - 10 V	

## 【DM-20】 SuperCap Fail-safe Electric Valve Actuator

- f. Output Signal Setting for Fully-open Position **FF0**
- Set the output signal value for fully-open position.
  - Setting Range: 000 to 4095.
    - The LED display is designed with hexadecimal format, so the value of 4095 is displayed as FFF.
  - Setting Steps:
    1. Press “DOWN” several times until **PAR** displays, then press “SET” once to enter parameter setting.
    2. Press “UP” or “DOWN” until **A 10** displays, then press “SET” once to enter analog signal setting.
    3. Press “UP or “DOWN” until **FF0** displays, then press “SET” enter output signal setting for fully-open mode.
    4. Press and hold “SET” around 3 sec, until the display shows the value and flashes.
    5. Press “UP” or “DOWN” to adjust the value until the signal meter receives the value of 20 mA, 5 V or 10 V according to the output signal type of **A-0** setting. Then press “SET” once to complete the output signal setting for fully-open position.
- ⚠ When the signal type of 0 - 20 mA, 0 - 5 V, or 0 - 10 V is selected, input the calibration signal value of 20 mA, 5 V or 10 V to perform the setup.**

Signal Type	Calibration Signal Value
4 - 20 mA	20 mA
0 - 20 mA	
1 - 5 V	5 V
0 - 5 V	
2 - 10 V	10 V
0 - 10 V	

## 【DM-20】 SuperCap Fail-safe Electric Valve Actuator

### g. Sensitivity Setting 5.0

- When the value of sensitivity (%) is lower, the resolution of the input signal will be higher, and relatively the dead band will be smaller. Excessive high resolution may cause the actuator to keep hunting and could not run to the desired position. If this situation happens, it is suggested to adjust the sensitivity setting.
- Setting Range: 0.1 % to 5.0 %.
  - When set to 0.1 %, it means that the allowable tolerance is  $\pm 0.1$  %, which is the highest sensitivity.
  - When set to 5.0 %, it means that the allowable tolerance is  $\pm 5$  %, which is the lowest sensitivity.
  - For example, if the sensitivity switch is set to 1% and the target position is 50 %, the valid sensitivity range will be from 49 % to 51 % as shown in the figure below.

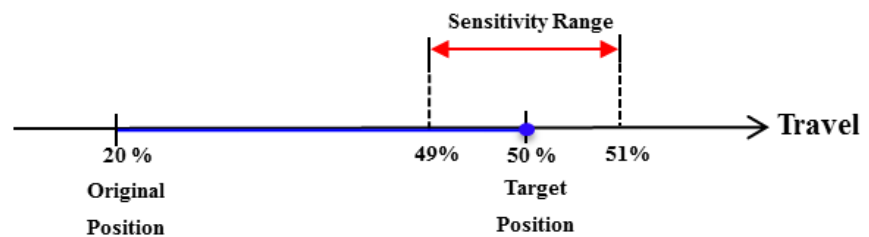

- Default Setting: 1.0%.
- Setting Steps:
  1. Press “DOWN” several times until PAR displays, then press “SET” once to enter parameter setting.
  2. Press “UP” or “DOWN” until R 10 displays, then press “SET” once to enter analog signal setting.
  3. Press “UP” or “DOWN” until 5.0 displays, then press “SET” once to enter sensitivity setting.
  4. Press and hold “SET” around 3 sec until the display shows the value and flashes.
  5. Press "UP" or "DOWN" to adjust the sensitivity setting value.
  6. Press "SET" to complete the sensitivity setting.



## 【DM-20】 SuperCap Fail-safe Electric Valve Actuator

### h. Signal Open Circuit Action AL 1

- Action when the input signal fails.
  - ⚠ **This function is only available when the input signal type A- 1 is set to 4 - 20 mA, 1 - 5 V or 2 - 10 V.**
- Setting Range: 000 to 002

Parameter Code	Instruction
<span style="border: 1px solid black; padding: 2px;">000</span>	Stay at the last position when input signal fails.
<span style="border: 1px solid black; padding: 2px;">001</span>	Run to the fully-open position when input signal fails.
<span style="border: 1px solid black; padding: 2px;">002</span>	Run to the fully-closed position when input signal fails.

- Default Setting: 002
- Setting Steps:
  1. Press “DOWN” several times until PAR displays, then press “SET” once to enter parameter setting.
  2. Press “UP” or “DOWN” until A 10 displays, then press “SET” once to enter analog signal setting.
  3. Press “UP” or “DOWN” until AL 1 displays, then press “SET” once to enter signal open circuit action mode.
  4. Press and hold “SET” around 3 sec until the display shows the value and flashes.
  5. Press “UP” or “DOWN” to adjust the value.
  6. Press "SET" to complete the signal open circuit action setting.

## 【DM-20】 SuperCap Fail-safe Electric Valve Actuator

[Fully-open / Fully-closed Limit Position Setting] HAn

 **This function is the same as section 5.1.3 Signal Setting for fully-open and fully-closed limit position of master control board. Repeat the setting is not required if it is completed.**

a. **Fully-Open Limit Position Setting** oPs

● Setting Steps:

1. Press “DOWN” several times until PAR displays, then press “SET” once to enter parameter setting.
2. Press “UP” or “DOWN” until HAn displays, then press “SET” once to enter Fully-open / Fully-closed Limit Position Setting.
3. Press “UP” or “DOWN” until oPs displays, then press “SET” once. “LOC” lamp will light on and “REM” lamp will light off.
4. Press “UP” and “DOWN” to perform open and close settings. Press “UP” to run the actuator toward opening direction and press “DOWN” to run the actuator toward closing direction.
5. Press and hold “UP” to run the actuator until it has reached fully-open position. Press and hold “SET” until “REM” lamp lights on and “LOC” lamp lights off to complete the fully-open limit position setting.

b. **Fully-Closed Limit Position Setting** LoS

● Setting Steps:

1. Press “DOWN” several times until PAR displays, then press “SET” once to enter parameter setting.
2. Press “UP” or “DOWN” until HAn displays, then press “SET” once to enter Fully-open / Fully-closed Limit Position Setting.
3. Press “UP” or “DOWN” until LoS displays, then press “SET” once. “LOC” lamp will light on and “REM” lamp will light off.
4. Press “UP” and “DOWN” to perform open and close settings. Press “UP” to run the actuator toward opening direction and press “DOWN” to run the actuator toward closing direction.
5. Press and hold “DOWN” to run the actuator until it has reached fully-closed position. Press and hold “SET” until “REM” lamp lights on and “LOC” lamp lights off to complete the fully-closed limit position setting.

## 【DM-20】 SuperCap Fail-safe Electric Valve Actuator

[Other] oEH

a. Time Delay Setting SPd

- Time delay controller enables the running time to be delayed from a standard to required time per system requirements.
- Setting Range: 000 to 999
  - 000: Disable time delay setting function
- Default Setting: 000
- Setting Steps:
  1. Press “DOWN” several times until PAR displays, press “SET” once to enter parameter setting.
  2. Press “UP” or “DOWN” until oEH displays, then press “SET” once.
  3. Press “UP” or “DOWN” until SPd displays, then press “SET” once.
  4. Press and hold “SET” around 3 sec until the display shows the value and flashes.
  5. Press “UP” or “DOWN” to choose the seconds.
    - ⚠ **If the setting time is less than the original rated time of the actuator, the actuator can't be executed according to the setting time.**
  6. Press “SET” to complete the time delay setting.

## 【DM-20】 SuperCap Fail-safe Electric Valve Actuator

### b. Motor Over-current (Real Time) CLR

- When the motor current value exceeds the set value, the motor will immediately stop and an error code will be displayed.
- Setting Range: 0 to 9.99A
- Default Setting: 1.30
- Setting Steps:
  1. Press “DOWN” several times until PAR displays, press “SET” once to enter parameter setting.
  2. Press “UP” or “DOWN” until oEH displays, then press “SET” once.
  3. Press “UP” or “DOWN” until CLR displays, then press “SET” once.
  4. Press and hold “SET” around 3 sec until the display shows the value and flashes.
  5. Press “UP” or “DOWN” to set desired current value.
  6. Press "SET" to complete the motor over-current (real time) setting.

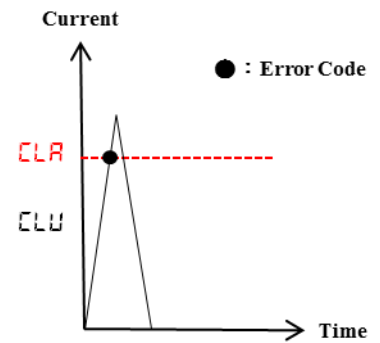

### c. Motor Over-current (Delay) CLU

- When the motor current exceeds the set value and remains for a period of time (motor over-current delay time), the motor will immediately stop and an error code will be displayed.
- Setting Range: 0 to 9.99A
- Default Setting: 100
- Setting Steps:
  1. Press “DOWN” several times until PAR displays, press “SET” once to enter parameter setting.
  2. Press “UP” or “DOWN” until oEH displays, then press “SET” once.
  3. Press “UP” or “DOWN” until CLU displays, then press “SET” once.
  4. Press and hold “SET” around 3 sec until the display shows the value and flashes.
  5. Press “UP” or “DOWN” to set desired current value.
  6. Press “SET” to complete the motor over-current (delay) setting.

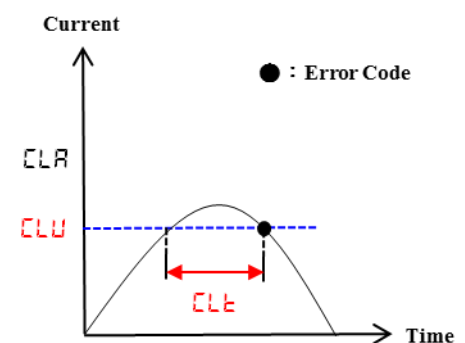

## 【DM-20】 SuperCap Fail-safe Electric Valve Actuator

- d. Delay Time Setting for Motor Over-current **CLE**
- The delay time for sending an alarm when motor over-current is detected.
  - Setting Range: 0 to 10 sec
  - Default Setting: **00**
  - Setting Steps:
    1. Press “DOWN” several time until **PAR** displays, press “SET” once to enter parameter setting.
    2. Press “UP” or “DOWN” until **oEH** displays, then press “SET” once.
    3. Press “UP” or “DOWN” until **CLE** displays, then press “SET” once.
    4. Press and hold “SET” around 3 sec until the display shows the value and flashes.
    5. Press “UP” or “DOWN” to set delay time.
    6. Press “SET” to complete the delay time setting for motor over-current.
- e. Firmware **UEr**
- Display the current firmware version.
  - Checking Steps:
    1. Press “DOWN” several times until **PAR** displays, then press “SET” once to enter parameter setting.
    2. Press “UP” or “DOWN” until **oEH** displays, then press “SET” once.
    3. Press “UP” or “DOWN” until **UEr** displays, then press “SET” to show the current firmware version.
- f. Restore Default Settings **rSE**
- **000**: The current setting value.
  - **001**: All parameters are restored to the default settings.
  - Setting Steps:
    1. Press “DOWN” several times until **PAR** displays, then press “SET” once to enter parameter setting.
    2. Press “UP” or “DOWN” until **rSE** displays.
    3. Press “SET” once until display the current setting value.
    4. Press “UP” to select **001**.
    5. Press “SET” once to complete the restore default settings.
      - ⚠ **Press “MODE” to return to the previous level if it is not required.**

# 【DM-20】 SuperCap Fail-safe Electric Valve Actuator

## 5.3.6 Warning Messages AL

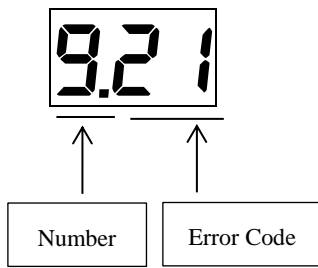

- Press “UP” or “DOWN” to switch the number from 0 to 9.
- Press and hold “SET” to clean all the error data.
- Press “MODE” to return to the first level.
- A maximum of 10 records can be recorded. Number 9 is the latest data and number 0 is the oldest data.
- The first digit shows the number of records, and the second and third one show the error code.
- The latest data is listed at the top and the oldest data at the bottom.

Error Code	Warning Message	Solution
<span style="border: 1px solid black; padding: 2px;">21</span>	Input Signal Fault	Input correct analog input signal per analog input signal type setting.
<span style="border: 1px solid black; padding: 2px;">22</span>	Output signal Fault	Please refer to the wiring diagram to confirm whether the input signal are connected correctly. (“AO-”to “AO+”).
<span style="border: 1px solid black; padding: 2px;">23</span>	Flash Memory Module and Operating Status Error	Replace a new master control board.
<span style="border: 1px solid black; padding: 2px;">27</span>	Low Input Voltage	1. Confirm the supply power. 2. Replace a new power board.
<span style="border: 1px solid black; padding: 2px;">30</span>	Installation Error of Potentiometer	Contact the seller.
<span style="border: 1px solid black; padding: 2px;">31</span>	Positioning Fault	Sensitivity setting is too low, please refer to 5.3.5 g (P.24) to adjust to higher sensitivity setting.
<span style="border: 1px solid black; padding: 2px;">32</span>	OPEN Potentiometer Fault	Confirm that if the torque is overloaded or the motor is locked. If this problem cannot be solved, please contact the seller.
<span style="border: 1px solid black; padding: 2px;">33</span>	CLOSE Potentiometer Fault	Confirm that if the torque is overloaded or the motor is locked. If this problem cannot be solved, please contact the seller.



## 【DM-20】 SuperCap Fail-safe Electric Valve Actuator

Error Code	Warning Message	Solution
34	Abnormal Current for Open direction	Use the manual device to check if the valve is stuck by foreign objects and remove them.
35	Abnormal Current for Closed direction	Use the manual device to check if the valve is stuck by foreign objects and remove them.
38	Signal Open Circuit	Check if the input signal is connected or not.
42	High Input voltage	1. Confirm the supply power. 2. Replace a new power board.
43	Power Failure	The actuator will run to a fail-safe position powered by a capacitor board when power is lost. Please check if the power supply is normal.
44	Capacitor Charging Abnormally	Replace a new capacitor board.
45	Exceeding the fully-open limit position during manual operation.	Refer to 4.1 manual operation instructions and manually or electrically operate the actuator to the fully-open limit position.
46	Exceeding the fully-closed limit position during manual operation.	Refer to 4.1 manual operation instructions and manually or electrically operate the actuator to the fully-closed limit position.

## 6 Troubleshooting

### On-Off / Floating Control

**Motor cannot operate or overheats.**

Possible problems	Solution
1. Motor shaft or bearing were stuck.	1. Replace a new motor.
2. Jammed pipe or stuck valve seat.	2. Check if any blockage or obstacle in pipe and remove.
3. The seating torque of valve increased due to oxidized seals and has resulted in a torque overload on actuator.	3. Use the manual device to check if the actuator can be operated, if not, replace the valve.

**The actuator operates properly, but the motor is getting hot.**

Possible problems	Solution
1. A torque overload caused by the valve.	1. This situation occurs frequently after the valve has been operating for a period of time. It is suggested to replace with a new valve.
2. Wrong power supply.	2. Check the power supply.
3. Actuator operates too frequently and exceeded duty cycle rating.	3. Adjust the system bandwidth, please refer to 3.5 (P.6).

**The valve cannot operate either electrical operation or manual operation.**

Possible problems	Solution
1. The actuator was mounted to the valve improperly.	1. Please refer to 4 (P.9) valve installation instructions.
2. The torque of valve is larger than the torque of actuator.	2. Replace with a new valve or a larger size actuator.

**None of the LED indicators on the master control board lit up after power is supplied.**

Possible problems	Solution
1. Wrong supply voltage.	1. Check the power supply.
2. Blown fuse.	2. Replace a new fuse.
3. Master control board.	3. Replace a new master control board.

## 【DM-20】 SuperCap Fail-safe Electric Valve Actuator

### The capacitor board is faulty.

Possible problems	Solution
1. The ambient temperature is too high or too low.	1. The actuator should be installed within the rated ambient temperature range of -20°C to +60°C (-4°F to 140°F).
2. The charging is abnormal.	2. Replace a new capacitor board.

### After manual operation is completed, when power is supplied, the actuator cannot operate.

Possible problems	Solution
Exceeding the fully-open or fully-closed limit position during manual operation and the LED warning indicator displays 4 long flashes and 5 short flashes or 4 long flashes and 6 short flashes in yellow.	4 long flashes and 5 short flashes in yellow: Refer to 4.1 manual operation instructions and manually or electrically operate the actuator to the fully-open limit position.  4 long flashes and 6 short flashes in yellow: Refer to 4.1 manual operation instructions and manually or electrically operate the actuator to the fully-closed limit position.

## 【DM-20】 SuperCap Fail-safe Electric Valve Actuator

### Modulating Control

The LED indicators on the modulating board are normal, but the actuator cannot operate or can only operate in either the fully-open or fully-closed position.

Possible problems	Solution
The signal wires are connected with reversed polarity, which means a signal failure.	Verify if the negative pole of signal input connected to "AI -" to "-" and "AI +" to "+" .

### Modulating control is not functioning

Possible problems	Solution
The modulating board is faulty, and the actuator cannot operate or can only operate in one direction.	Replace a new modulating board

After manual operation is completed, when power is supplied, the actuator cannot operate.

Possible problems	Solution
Exceeding the fully-open or fully-closed limit position during manual operation and it shows E45 or E46 on the LED display.	E45: Refer to 4.1 manual operation instructions and manually or electrically operate the actuator to the fully-open limit position.  E46: Refer to 4.1 manual operation instructions and manually or electrically operate the actuator to the fully-closed limit position.

## 7 Warranty

Sun Yeh Ele. Co. Ltd. warrants that for a period of twelve months from the date of manufacture it will either repair or replace, at its option, any of its products which prove to be defective in material or workmanship. This warranty does not cover damage resulting from causes such as abuse, misuse, modification or tampering by users. This warranty is extended only to the immediate purchaser of the Sun Yeh product and is not transferable. To obtain service under this warranty, the purchaser must first acquire a return authorization from Sun Yeh. Products must be returned to Sun Yeh under freight prepaid.

This warranty is in lieu of all other obligations, liabilities or expressed warranties. Any implied warranties, including any implied warranty of merchantability are hereby expressly excluded. In no event shall Sun Yeh be liable for special, incidental or consequential damages arising in connection with the use of its products, or for any delay in the performance of this warranty due to cause beyond its control.

## 8 Disposal

Please obey the local environment regulation for equipment scrapping.



**SUN YEH ELECTRICAL IND. CO., LTD.**

No.68, Ln. 854, Sec. 1, Shatian Rd., Dadu Dist.,  
Taichung City 432403, Taiwan  
Tel: +886-4-26985666 Fax: +886-4-26983668  
E-mail: [service@sunyeh.com](mailto:service@sunyeh.com)

[www.sunyeh.com](http://www.sunyeh.com)

